

# Technical Information

## Ceraphant PTC31B, PTP31B

Process pressure measurement



Pressure switch for safe measurement and monitoring of absolute and gauge pressure

### Application

The Ceraphant is a pressure switch for the measurement of absolute and gauge pressure in gases, vapors, liquids and dust. The Ceraphant can be used internationally thanks to a wide range of approvals and process connections.

### Your benefits

- High reproducibility and long-term stability
- Reference accuracy: up to 0.3%
- Customized measuring ranges
  - Turn down up to 5:1
  - Sensor for measuring ranges up to 400 bar (6 000 psi)
- Housing and process isolating diaphragm made of 316L

Operation and electrical connection in accordance with VDMA 24574-1:2008



## Table of contents

<b>Document information</b> . . . . .	<b>4</b>	Measuring uncertainty for small absolute pressure	
Document function . . . . .	4	measuring ranges . . . . .	19
Symbols used . . . . .	4	Influence of the installation position . . . . .	19
Documentation . . . . .	5	Resolution . . . . .	19
Terms and abbreviations . . . . .	6	Reference accuracy . . . . .	19
Turn down calculation . . . . .	7	Thermal change of the zero output and the output span . . . . .	19
		Long-term stability . . . . .	19
		Switch-on time . . . . .	20
<b>Function and system design</b> . . . . .	<b>8</b>	<b>Installation</b> . . . . .	<b>20</b>
Measuring principle - process pressure measurement . . . . .	8	Installation conditions . . . . .	20
Measuring system . . . . .	8	Influence of the installation position . . . . .	20
Device features . . . . .	9	Mounting location . . . . .	20
Product design . . . . .	10	Mounting instructions for oxygen applications . . . . .	22
System integration . . . . .	10		
		<b>Environment</b> . . . . .	<b>23</b>
<b>Input</b> . . . . .	<b>11</b>	Ambient temperature range . . . . .	23
Measured variable . . . . .	11	Storage temperature range . . . . .	23
Measuring range . . . . .	11	Climate class . . . . .	23
		Degree of protection . . . . .	23
		Vibration resistance . . . . .	23
		Electromagnetic compatibility . . . . .	23
<b>Output</b> . . . . .	<b>13</b>		
Output signal . . . . .	13	<b>Process</b> . . . . .	<b>24</b>
Range of adjustment . . . . .	13	Process temperature range for devices with ceramic	
Switching capacity . . . . .	13	process isolating diaphragm . . . . .	24
Signal range 4 to 20 mA . . . . .	13	Process temperature range for devices with metallic	
Load (for devices with analog output) . . . . .	13	process isolating diaphragm . . . . .	24
Signal on alarm 4 to 20 mA . . . . .	14	Pressure specifications . . . . .	24
Dead time, time constant . . . . .	14		
Dynamic behavior . . . . .	14	<b>Mechanical construction</b> . . . . .	<b>25</b>
Dynamic behavior of switch output . . . . .	14	Design, dimensions . . . . .	25
Damping . . . . .	14	Electrical connection . . . . .	25
		Housing . . . . .	26
		Process connections with internal, ceramic process	
		isolating diaphragm . . . . .	27
		Process connections with internal, ceramic process	
		isolating diaphragm . . . . .	28
		Process connections with internal, ceramic process	
		isolating diaphragm . . . . .	29
		Process connections with internal, ceramic process	
		isolating diaphragm . . . . .	29
		Process connections with internal, metal process isolating	
		diaphragm . . . . .	30
		Process connections with internal, metal process isolating	
		diaphragm . . . . .	31
		Process connections with internal, metal process isolating	
		diaphragm . . . . .	32
		Process connections with internal, metal process isolating	
		diaphragm . . . . .	32
		Process connections with flush-mounted, metal process	
		isolating diaphragm . . . . .	33
		Materials in contact with process . . . . .	34
		Materials not in contact with process . . . . .	35
		Cleaning . . . . .	36
<b>Performance characteristics of ceramic process</b>		<b>Operability</b> . . . . .	<b>37</b>
<b>isolating diaphragm</b> . . . . .	<b>17</b>	Operation with local display . . . . .	37
Reference operating conditions . . . . .	17		
Measuring uncertainty for small absolute pressure			
measuring ranges . . . . .	17		
Influence of the installation position . . . . .	17		
Resolution . . . . .	17		
Reference accuracy . . . . .	17		
Thermal change of the zero output and the output span . . . . .	17		
Long-term stability . . . . .	17		
Switch-on time . . . . .	18		
<b>Performance characteristics of metallic process</b>			
<b>isolating diaphragm</b> . . . . .	<b>19</b>		
Reference operating conditions . . . . .	19		

Functions of switch output . . . . .	38
<b>Certificates and approvals . . . . .</b>	<b>40</b>
CE mark . . . . .	40
RoHS . . . . .	40
RCM-Tick marking . . . . .	40
Pressure Equipment Directive 2014/68/EU (PED) . . . . .	40
Other standards and guidelines . . . . .	41
CRN approval . . . . .	41
Calibration unit . . . . .	41
Calibration . . . . .	42
Inspection certificates . . . . .	42
<b>Ordering information . . . . .</b>	<b>42</b>
Scope of delivery . . . . .	42
<b>Accessories . . . . .</b>	<b>43</b>
Weld-in adapter . . . . .	43
M12 plug connectors . . . . .	43
<b>Documentation . . . . .</b>	<b>44</b>
Field of Activities . . . . .	44
Technical Information . . . . .	44
Operating Instructions . . . . .	44
Brief Operating Instructions . . . . .	44





## Document information

### Document function



The document contains all the technical data on the device and provides an overview of the accessories and other products that can be ordered for the device.

### Symbols used







#### Safety symbols

Symbol	Meaning
	<b>DANGER!</b> This symbol alerts you to a dangerous situation. Failure to avoid this situation will result in serious or fatal injury.
	<b>WARNING!</b> This symbol alerts you to a dangerous situation. Failure to avoid this situation can result in serious or fatal injury.
	<b>CAUTION!</b> This symbol alerts you to a dangerous situation. Failure to avoid this situation can result in minor or medium injury.
	<b>NOTE!</b> This symbol contains information on procedures and other facts which do not result in personal injury.

#### Electrical symbols

Symbol	Meaning	Symbol	Meaning
	<b>Protective ground connection</b> A terminal which must be connected to ground prior to establishing any other connections.		<b>Ground connection</b> A grounded terminal which, as far as the operator is concerned, is grounded via a grounding system.

#### Symbols for certain types of information

Symbol	Meaning
	<b>Permitted</b> Procedures, processes or actions that are permitted.
	<b>Forbidden</b> Procedures, processes or actions that are forbidden.
	<b>Tip</b> Indicates additional information.
	Reference to documentation
	Reference to page
	Reference to graphic
	Visual inspection

#### Symbols in graphics

Symbol	Meaning
1, 2, 3 ...	Item numbers
1. 2. 3. ...	Series of steps
A, B, C, ...	Views

## Documentation



The document types listed are available:

In the Download Area of the Endress+Hauser Internet site: [www.endress.com](http://www.endress.com) → Download

### **Brief Operating Instructions (KA): getting the 1st measured value quickly**

The Brief Operating Instructions contain all the essential information from incoming acceptance to initial commissioning.

### **Operating Instructions (BA): your comprehensive reference**

These Operating Instructions contain all the information that is required in various phases of the life cycle of the device: from product identification, incoming acceptance and storage, to mounting, connection, operation and commissioning through to troubleshooting, maintenance and disposal.

Terms and abbreviations

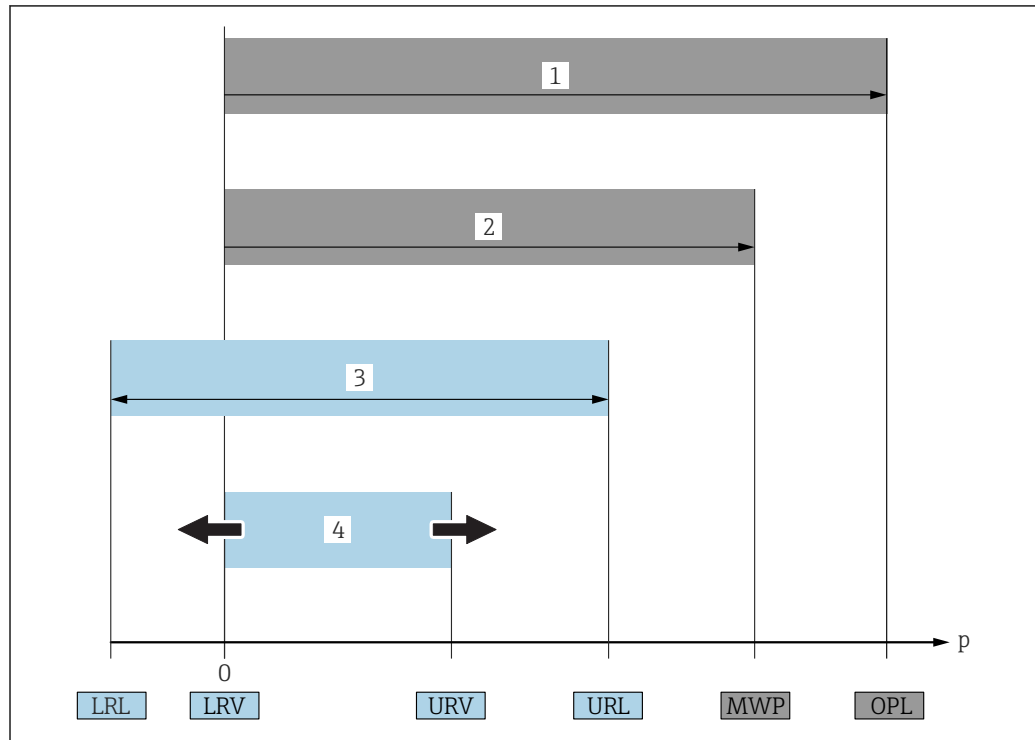

A0029505

Item	Term/ abbreviation	Explanation
1	OPL	The OPL (over pressure limit = sensor overload limit) for the measuring device depends on the lowest-rated element, with regard to pressure, of the selected components, i.e. the process connection has to be taken into consideration in addition to the measuring cell. Also observe pressure-temperature dependency. For the relevant standards and additional notes, see the "Pressure specifications" section → 24 . The OPL may only be applied for a limited period of time.
2	MWP	The MWP (maximum working pressure) for the sensors depends on the lowest-rated element, with regard to pressure, of the selected components, i.e. the process connection has to be taken into consideration in addition to the measuring cell. Also observe pressure-temperature dependency. For the relevant standards and additional notes, see the "Pressure specifications" section → 24 . The MWP may be applied at the device for an unlimited period. The MWP can also be found on the nameplate.
3	Maximum sensor measuring range	Span between LRL and URL This sensor measuring range is equivalent to the maximum calibratable/adjustable span.
4	Calibrated/adjusted span	Span between LRV and URV Factory setting: 0 to URL Other calibrated spans can be ordered as customized spans.
p	-	Pressure
-	LRL	Lower range limit
-	URL	Upper range limit
-	LRV	Lower range value
-	URV	Upper range value
-	TD (turn down)	Turn down Example - see the following section.

**Turn down calculation**

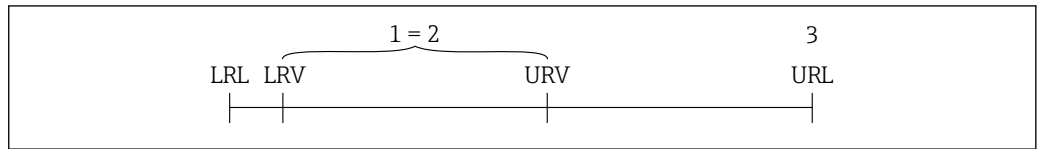

A0029545

- 1 *Calibrated/adjusted span*
- 2 *Zero point-based span*
- 3 *URL sensor*

**Example**

- Sensor: 10 bar (150 psi)
- Upper range value (URL) = 10 bar (150 psi)
- Calibrated/adjusted span: 0 to 5 bar (0 to 75 psi)
- Lower range value (LRV) = 0 bar (0 psi)
- Upper range value (URV) = 5 bar (75 psi)

Turn down (TD):

$$TD = \frac{URL}{|URV - LRV|}$$

$$TD = \frac{10 \text{ bar (150 psi)}}{|5 \text{ bar (75 psi)} - 0 \text{ bar (0 psi)}|} = 2$$

In this example, the TD is 2:1.  
This span is based on the zero point.

## Function and system design

### Measuring principle - process pressure measurement

#### Devices with ceramic process isolating diaphragm (Ceraphire®)

The ceramic sensor is an oil-free sensor, i.e. the process pressure acts directly on the robust ceramic process isolating diaphragm and causes it to deflect. A pressure-dependent change in capacitance is measured at the electrodes of the ceramic substrate and the process isolating diaphragm. The measuring range is determined by the thickness of the ceramic process isolating diaphragm.

#### Advantages:

- Guaranteed overload resistance up to 40 times the nominal pressure
- The ultrapure 99.9% ceramic (Ceraphire®, see also "www.endress.com/ceraphire") ensures:
  - Extremely high chemical durability
  - High mechanical durability
- Can be used in absolute vacuum
- Small measuring ranges

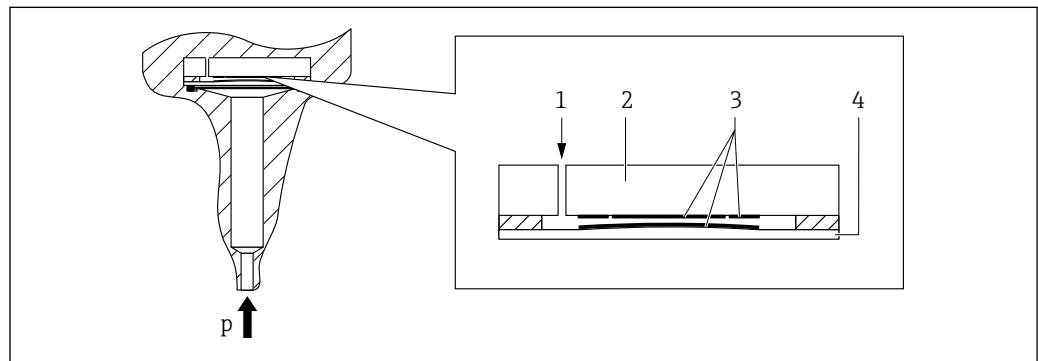

A0020465

- 1 Air pressure (gauge pressure sensors)
- 2 Ceramic substrate
- 3 Electrodes
- 4 Ceramic process isolating diaphragm

#### Devices with metallic process isolating diaphragm

The process pressure deflects the metal process isolating diaphragm of the sensor and a fill fluid transfers the pressure to a Wheatstone bridge (semiconductor technology). The pressure-dependent change in the bridge output voltage is measured and evaluated.

#### Advantages:

- Can be used for high process pressures
- Fully welded sensor
- Slim, flush-mounted process connections available

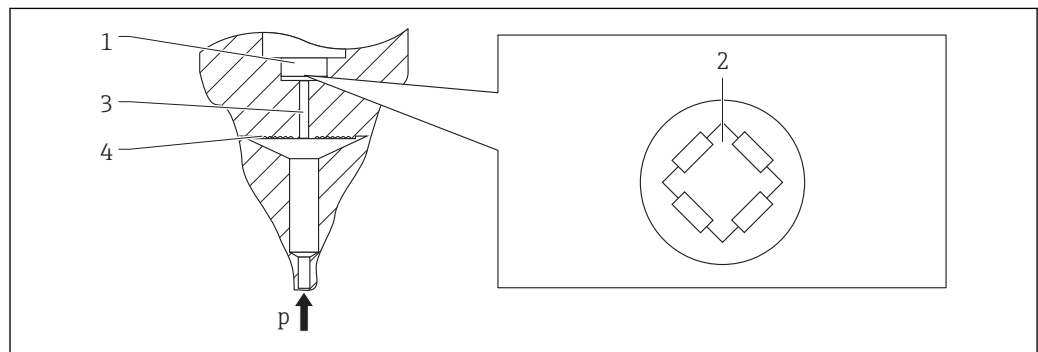

A0016448

- 1 Silicon measuring element, substrate
- 2 Wheatstone bridge
- 3 Channel with fill fluid
- 4 Metal process isolating diaphragm

### Measuring system

A complete measuring system comprises:



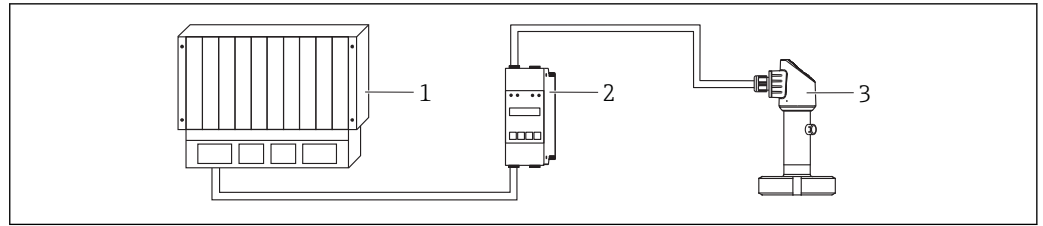

A0021924

- 1 PLC (programmable logic control)
- 2 e.g. RMA42 / RIA45 (if required)
- 3 Device



### Device features

	PTC31B
Field of application	Gauge pressure and absolute pressure
Process connections	<ul style="list-style-type: none"> <li>▪ Thread</li> <li>▪ Thread ANSI</li> <li>▪ Thread M24 x 1.5</li> <li>▪ Thread JIS</li> </ul>
Measuring ranges	From 0 to +100 mbar (0 to +1.5 psi) to 0 to +40 bar (0 to +600 psi).
OPL (depends on the measuring range)	Max. 0 to +60 bar (0 to +900 psi)
MWP	Max. 0 to +40 bar (0 to +600 psi)
Process temperature range	-25 to +100 °C (-13 to +212 °F)
Ambient temperature range	-20 to +70 °C (-4 to +158 °F) (in the range of the temperature limits with restrictions in optical properties, such as display speed and contrast)
Reference accuracy	<ul style="list-style-type: none"> <li>▪ Standard: 0.5%</li> <li>▪ Platinum: 0.3%</li> </ul>
Supply voltage	10 to 30 V DC
Output	<ul style="list-style-type: none"> <li>▪ 1 x PNP switch output (three-wire)</li> <li>▪ 2 x PNP switch output (four-wire)</li> <li>▪ 1 x PNP switch output + 4 to 20 mA output (four-wire)</li> </ul>
Material	<ul style="list-style-type: none"> <li>▪ Housing made from 316L (1.4404)</li> <li>▪ Process connections made from 316L</li> <li>▪ Process isolating diaphragm made from Al<sub>2</sub>O<sub>3</sub> aluminum-oxide ceramic, (Ceraphire®), ultrapure 99.9 %</li> </ul>
Options	<ul style="list-style-type: none"> <li>▪ Certificate of calibration</li> <li>▪ Cleaned from oil+grease</li> <li>▪ Min. alarm current setting</li> <li>▪ 3.1 Material certificates</li> <li>▪ Cleaned for O<sub>2</sub> service</li> </ul>

	PTP31B
Field of application	Gauge pressure and absolute pressure
Process connections	<ul style="list-style-type: none"> <li>▪ Thread ISO 228, also flush-mount</li> <li>▪ Thread ASME</li> <li>▪ Thread DIN 13</li> <li>▪ Thread ASME</li> <li>▪ Thread JIS</li> </ul>
Measuring ranges	From 0 to +400 mbar (0 to +6 psi) to 0 to +400 bar (0 to +6 000 psi).
OPL (depends on the measuring range)	Max. 0 to +600 bar (0 to +9 000 psi)
MWP	Max. 0 to +400 bar (0 to +6 000 psi)
Process temperature range	-40 to +100 °C (-40 to +212 °F)
Ambient temperature range	-20 to +70 °C (-4 to +158 °F) (in the range of the temperature limits with restrictions in optical properties, such as display speed and contrast)

PTP31B	
Reference accuracy	<ul style="list-style-type: none"> <li>▪ Standard: 0.5%</li> <li>▪ Platinum: 0.3%</li> </ul>
Supply voltage	10 to 30 V DC
Output	<ul style="list-style-type: none"> <li>▪ 1 x PNP switch output (three-wire)</li> <li>▪ 2 x PNP switch output (four-wire)</li> <li>▪ 1 x PNP switch output + 4 to 20 mA output (four-wire)</li> </ul>
Material	<ul style="list-style-type: none"> <li>▪ Housing made from 316L (1.4404)</li> <li>▪ Process connections made from 316L (1.4404)</li> <li>▪ Process isolating diaphragm made from 316L (1.4435)</li> </ul>
Options	<ul style="list-style-type: none"> <li>▪ Certificate of calibration</li> <li>▪ Cleaned from oil+grease</li> <li>▪ Min. alarm current setting</li> <li>▪ 3.1 Material certificates</li> </ul>

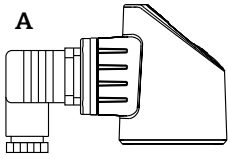
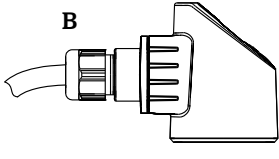
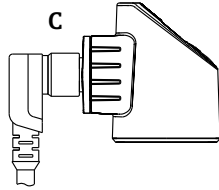
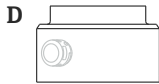
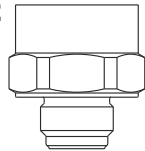
**Product design**

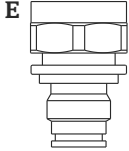
Overview	Position	Description
   <p style="text-align: right; font-size: small;">A0022015</p>	A	Valve plug
	B	Cable
	C	M12 plug Housing cap made of plastic
  <p style="text-align: right; font-size: small;">A0027226</p>	D	Housing Process connection (sample illustration)
	E	
  <p style="text-align: right; font-size: small;">A0027215</p>	D	
	E	

**System integration**

The device can be given a tag name (max. 8 alphanumeric characters).

Description	Option <sup>1)</sup>
Measuring point (TAG), see additional specifications	Z1

1) Product Configurator, order code for "Identification"

## Input

### Measured variable

### Measured process variable

Gauge pressure or absolute pressure

### Calculated process variable

Pressure

### Measuring range

### Ceramic process isolating diaphragm

Sensor	Device	Maximum Sensor measuring range		Lowest calibratable span <sup>1)</sup>	MWP	OPL	Factory settings <sup>2)</sup>	Option <sup>3)</sup>
		lower (LRL)	upper (URL)					
		[bar (psi)]	[bar (psi)]					
<b>Devices for gauge pressure measurement</b>								
100 mbar (1.5 psi) <sup>4)</sup>	PTC31B	-0.1 (-1.5)	+0.1 (+1.5)	0.02 (0.3)	2.7 (40.5)	4 (60)	0 to 100 mbar (0 to 1.5 psi)	1C
250 mbar (4 psi) <sup>5)</sup>	PTC31B	-0.25 (-4)	+0.25 (+4)	0.05 (1)	3.3 (49.5)	5 (75)	0 to 250 mbar (0 to 4 psi)	1E
400 mbar (6 psi) <sup>6)</sup>	PTC31B	-0.4 (-6)	+0.4 (+6)	0.08 (1.2)	5.3 (79.5)	8 (120)	0 to 400 mbar (0 to 6 psi)	1F
1 bar (15 psi) <sup>6)</sup>	PTC31B	-1 (-15)	+1 (+15)	0.2 (3)	6.7 (100.5)	10 (150)	0 to 1 bar (0 to 15 psi)	1H
2 bar (30 psi) <sup>6)</sup>	PTC31B	-1 (-15)	+2 (+30)	0.4 (0.6)	12 (180)	18 (270)	0 to 2 bar (0 to 30 psi)	1K
4 bar (60 psi) <sup>6)</sup>	PTC31B	-1 (-15)	+4 (+60)	0.8 (1.2)	16.7 (250.5)	25 (375)	0 to 4 bar (0 to 60 psi)	1M
10 bar (150 psi) <sup>6)</sup>	PTC31B	-1 (-15)	+10 (+150)	2 (30)	26.7 (400.5)	40 (600)	0 to 10 bar (0 to 150 psi)	1P
40 bar (600 psi) <sup>6)</sup>	PTC31B	-1 (-15)	+40 (+600)	8 (120)	40 (600)	60 (900)	0 to 40 bar (0 to 600 psi)	1S
<b>Devices for absolute pressure measurement</b>								
100 mbar (1.5 psi) <sup>6)</sup>	PTC31B	0	+0.1 (+1.5)	0.1 (1.5)	2.7 (40.5)	4 (60)	0 to 100 mbar (0 to 1.5 psi)	2C
250 mbar (4 psi) <sup>6)</sup>	PTC31B	0	+0.25 (+4)	0.25 (4)	3.3 (49.5)	5 (75)	0 to 250 mbar (0 to 4 psi)	2E
400 mbar (6 psi) <sup>6)</sup>	PTC31B	0	+0.4 (+6)	0.4 (6)	5.3 (79.5)	8 (120)	0 to 400 mbar (0 to 6 psi)	2F
1 bar (15 psi) <sup>6)</sup>	PTC31B	0	+1 (+15)	0.4 (6)	6.7 (100.5)	10 (150)	0 to 1 bar (0 to 15 psi)	2H
2 bar (30 psi) <sup>6)</sup>	PTC31B	0	+2 (+30)	0.4 (0.6)	12 (180)	18 (270)	0 to 2 bar (0 to 30 psi)	2K
4 bar (60 psi) <sup>6)</sup>	PTC31B	0	+4 (+60)	0.8 (1.2)	16.7 (250.5)	25 (375)	0 to 4 bar (0 to 60 psi)	2M
10 bar (150 psi) <sup>6)</sup>	PTC31B	0	+10 (+150)	2 (30)	26.7 (400.5)	40 (600)	0 to 10 bar (0 to 150 psi)	2P
40 bar (600 psi) <sup>6)</sup>	PTC31B	0	+40 (+600)	8 (120)	40 (600)	60 (900)	0 to 40 bar (0 to 600 psi)	2S

- 1) Highest turn down that can be set at the factory: 5:1. The turn down is preset and cannot be changed.
- 2) Other measuring ranges (e.g. -1 to +5 bar (-15 to 75 psi)) can be ordered with customer-specific settings (see the Product Configurator, order code for "Calibration; Unit" option "J"). It is possible to invert the output signal (LRV = 20 mA; URV = 4 mA). Prerequisite: URV < LRV
- 3) Product Configurator, order code for "Sensor range"
- 4) Vacuum resistance: 0.7 bar (10.5 psi) abs
- 5) Vacuum resistance: 0.5 bar (7.5 psi) abs
- 6) Vacuum resistance: 0 bar (0 psi) abs

*Maximum turn down which can be ordered for absolute pressure and gauge pressure sensors*

Devices for gauge pressure measurement

- 6 bar (90 psi), 16 bar (240 psi), 25 bar (375 psi): TD 1:1 to TD 2.5:1
- All other measuring ranges: TD 1:1 to TD 5:1

Devices for absolute pressure measurement

- 100 mbar (1.5 psi), 250 mbar (4 psi), 400 mbar (6 psi): TD 1:1
- 1 bar (15 psi): TD 1:1 to TD 2.5:1
- All other measuring ranges: TD 1:1 to TD 5:1

## Metal process isolating diaphragm

Sensor	Device	Maximum Sensor measuring range		Lowest calibratable span <sup>1)</sup>	MWP	OPL	Factory settings <sup>2)</sup>	Option <sup>3)</sup>
		lower (LRL)	upper (URL)					
		[bar (psi)]	[bar (psi)]	[bar (psi)]	[bar (psi)]	[bar (psi)]		
<b>Devices for gauge pressure measurement</b>								
400 mbar (6 psi) <sup>4)</sup>	PTP31B	-0.4 (-6)	+0.4 (+6)	0.4 (6)	1 (15)	1.6 (24)	0 to 400 mbar (0 to 6 psi)	1F
1 bar (15 psi) <sup>4)</sup>	PTP31B	-1 (-15)	+1 (+15)	0.4 (6)	2.7 (40.5)	4 (60)	0 to 1 bar (0 to 15 psi)	1H
2 bar (30 psi) <sup>4)</sup>	PTP31B	-1 (-15)	+2 (+30)	0.4 (6)	6.7 (100.5)	10 (150)	0 to 2 bar (0 to 30 psi)	1K
4 bar (60 psi) <sup>4)</sup>	PTP31B	-1 (-15)	+4 (+60)	0.8 (12)	10.7 (160.5)	16 (240)	0 to 4 bar (0 to 60 psi)	1M
10 bar (150 psi) <sup>4)</sup>	PTP31B	-1 (-15)	+10 (+150)	2 (30)	25 (375)	40 (600)	0 to 10 bar (0 to 150 psi)	1P
40 bar (600 psi) <sup>4)</sup>	PTP31B	-1 (-15)	+40 (+600)	8 (120)	100 (1500)	160 (2400)	0 to 40 bar (0 to 600 psi)	1S
100 bar (1 500 psi) <sup>4)</sup>	PTP31B	-1 (-15)	+100 (+1500)	20 (300)	100 (1500)	160 (2400)	0 to 100 bar (0 to 1 500 psi)	1U
400 bar (6 000 psi) <sup>4)</sup>	PTP31B	-1 (-15)	+400 (+6000)	80 (1200)	400 (6000)	600 (9000)	0 to 400 bar (0 to 6 000 psi)	1W
<b>Devices for absolute pressure measurement</b>								
400 mbar (6 psi) <sup>4)</sup>	PTP31B	0 (0)	0.4 (+6)	0.4 (6)	1 (15)	1.6 (24)	0 to 400 mbar (0 to 6 psi)	2F
1 bar (15 psi) <sup>4)</sup>	PTP31B	0 (0)	1 (+15)	0.4 (6)	2.7 (40.5)	4 (60)	0 to 1 bar (0 to 15 psi)	2H
2 bar (30 psi) <sup>4)</sup>	PTP31B	0 (0)	2 (+30)	0.4 (6)	6.7 (100.5)	10 (150)	0 to 2 bar (0 to 30 psi)	2K
4 bar (60 psi) <sup>4)</sup>	PTP31B	0 (0)	4 (+60)	0.8 (12)	10.7 (160.5)	16 (240)	0 to 4 bar (0 to 60 psi)	2M
10 bar (150 psi) <sup>4)</sup>	PTP31B	0 (0)	10 (+150)	2 (30)	25 (375)	40 (600)	0 to 10 bar (0 to 150 psi)	2P
40 bar (600 psi) <sup>4)</sup>	PTP31B	0 (0)	+40 (+600)	8 (120)	100 (1500)	160 (2400)	0 to 40 bar (0 to 600 psi)	2S
100 bar (1 500 psi) <sup>4)</sup>	PTP31B	0 (0)	+100 (+1500)	20 (300)	100 (1500)	160 (2400)	0 to 100 bar (0 to 1 500 psi)	2U
400 bar (6 000 psi) <sup>4)</sup>	PTP31B	0 (0)	+400 (+6000)	80 (1200)	400 (6000)	600 (9000)	0 to 400 bar (0 to 6 000 psi)	2W

- 1) Highest turn down that can be set at the factory: 5:1. The turn down is preset and cannot be changed.
- 2) Other measuring ranges (e.g. -1 to +5 bar (-15 to 75 psi)) can be ordered with customer-specific settings (see the Product Configurator, order code for "Calibration: Unit" option "J"). It is possible to invert the output signal (LRV = 20 mA; URV = 4 mA). Prerequisite: URV < LRV
- 3) Product Configurator, order code for "Sensor range"
- 4) Vacuum resistance: 0.01 bar (0.145 psi) abs

*Maximum turn down which can be ordered for absolute pressure and gauge pressure sensors*

Ranges 0.5%/0.3%: TD 1:1 to TD 5:1

## Output

Output signal	Description	Option <sup>1)</sup>
	PNP switch output + 4 to 20 mA output (4-wire)	3
	PNP switch output (3-wire)	4
	2 x PNP switch output (4-wire)	5

1) Product Configurator, order code for "Output"

### Range of adjustment

- Switch output  
Switch point (SP): 0.5 to 100 % in increments of 0.1% (min. 1 mbar \* (0.015 psi)) of the upper range limit (URL) switchback point (RSP): 0 to 99.5% in increments of 0.1% (min. 1 mbar \* (0.015 psi)) of the upper range limit (URL)  
Minimum distance between SP and RSP: 0.5 % URL
  - Analog output (if available)  
Lower range value (LRV) and upper range value (URV) can be set anywhere within the sensor range (LRL - URL). Turn down for analog output up to 5:1 of upper sensor limit (URL).
  - Factory setting (if no customer-specific setting is ordered):  
Switch point SP1: 90 %; switchback point RP1: 10 %;  
Switch point SP2: 95 %; switchback point RP2: 15 %;  
Analog output: LRV 0 %; URV 100 %
- \* For measuring ranges with a negative gauge pressure up to 4 bar (60 psi), the increment when setting the switch point is min. 10 mbar (0.15 psi)

### Switching capacity

- Switch state ON:  $I_a \leq 250 \text{ mA}$ ; switch state OFF:  $I_a \leq 1 \text{ mA}$
- Switch cycles: >10,000,000
- Voltage drop PNP:  $\leq 2 \text{ V}$
- Overload protection: Automatic load testing of switching current;
  - Max. capacitance load: 14  $\mu\text{F}$  at max. supply voltage (without resistive load)
  - Max. cycle duration: 0.5 s; min.  $t_{\text{on}}$ : 4 ms
  - Periodic disconnection from protective circuit in the event of overcurrent ( $f = 2 \text{ Hz}$ ) and "F804" displayed

### Signal range 4 to 20 mA

3.8 mA to 20.5 mA

### Load (for devices with analog output)

The maximum load resistance depends on the terminal voltage and is calculated according to the following formula:

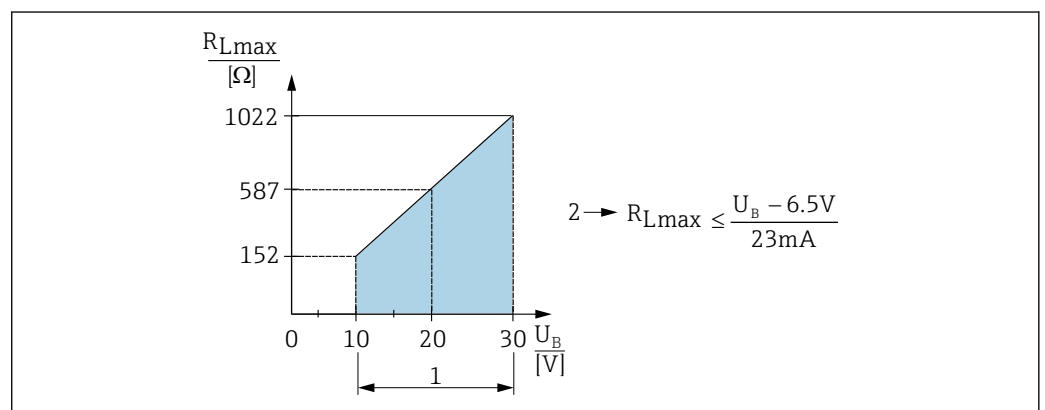

- 1 Power supply 10 to 30 V DC  
2  $R_{Lmax}$  maximum load resistance  
 $U_B$  Supply voltage

If load is too great:

- Error current is output and "S803" displayed (output: MIN alarm current)
- Periodic checking to establish if it is possible to quit fault state

**Signal on alarm 4 to 20 mA**

The response of the output to error is regulated in accordance with NAMUR NE43.

The behavior of the current output in case of fault is defined by the following parameters:

- FCU "MIN": Lower alarm current ( $\leq 3.6$  mA) (optional, see the following table)
- FCU "MAX" (factory setting): Upper alarm current ( $\geq 21$  mA)
- FCU "HLD" (HOLD) (optional, see the following table): Last measured current value is held. When the device starts, the current output is set to "Lower alarm current" ( $\leq 3.6$  mA).

**alarm current**

Device	Description	Option
PTC31B PTP31B	Adjusted min. alarm current	IA <sup>1)</sup>
PTC31B PTP31B	1 low $\leq 3.6$ mA 2 high $\geq 21$ mA 3 last current value	U <sup>2)</sup>

1) Product Configurator order code for "Service"

2) Product Configurator order code for "Calibration/unit"

**Dead time, time constant**

Presentation of the dead time and the time constant:

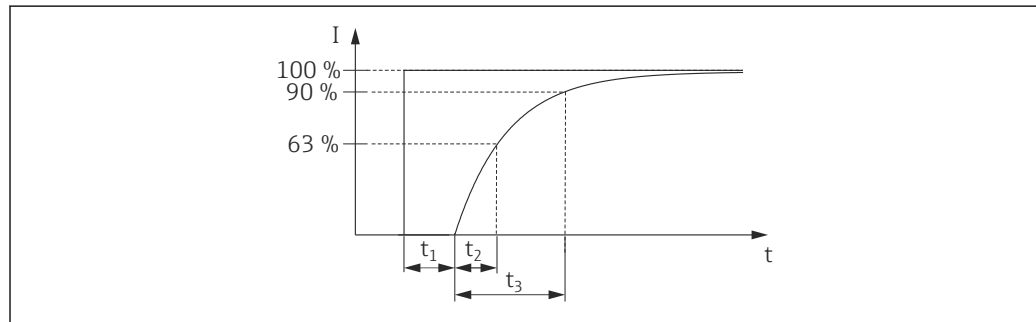

A0019786

**Dynamic behavior**

**Analog electronics**

Dead time ( $t_1$ ) [ms]	Time constant (T63), $t_2$ [ms]	Time constant (T90), $t_3$ [ms]
7 ms	11 ms	16 ms

**Dynamic behavior of switch output**

PNP switch output and 2 x PNP switch output: response time  $\leq 20$  ms

**Damping**

Once the supply voltage has been applied, damping for the first measured value is at 0 i.e. the first measured value applied always corresponds to the actual measured value (regardless of damping).

A damping affects all outputs (output signal, display):

- via local display infinitely variable 0 to 999.9 s
- Factory setting: 2.0 s

## Power supply

**⚠ WARNING**

**Limitation of electrical safety due to incorrect connection!**

- ▶ In accordance with IEC/EN61010 a separate circuit breaker must be provided for the device .
- ▶ Protective circuits against reverse polarity, HF influences and overvoltage peaks are integrated.
- ▶ The device must be operated with a 630 mA fine-wire fuse (slow-blow).

**Terminal assignment**

*1 x PNP switch output R1*

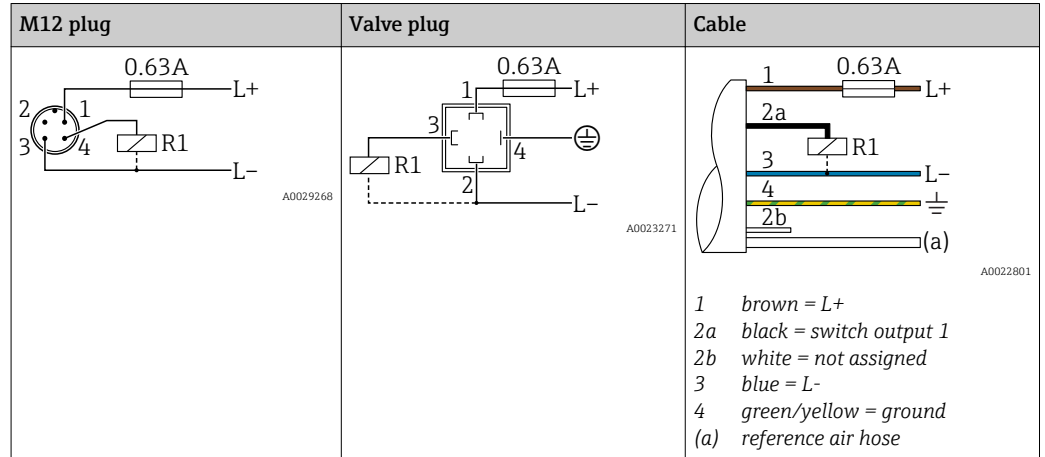

*2 x PNP switch outputs R1 and R2*

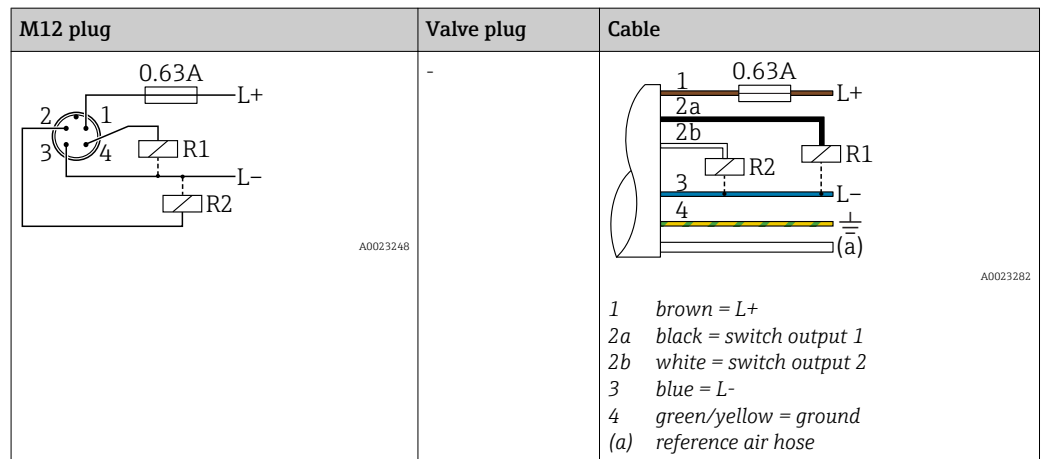

*1 x PNP switch output R1 with additional analog output 4 to 20 mA (active)*

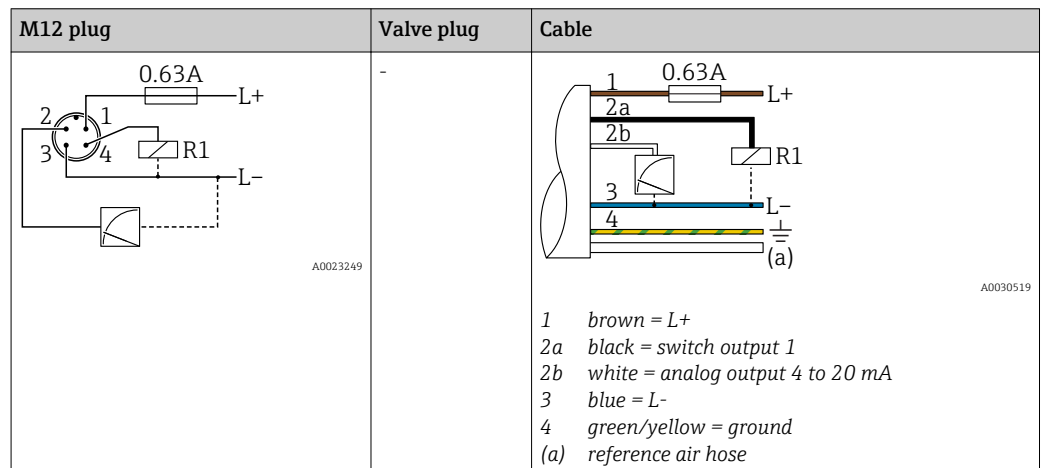

**Supply voltage** Supply voltage: 10 to 30 V DC

**Current consumption and alarm signal**

Intrinsic power consumption	Alarm current (for devices with analog output)
≤ 60 mA	≥21 mA (factory setting)

**Power supply fault**

- Behavior in the event of overvoltage (>30 V):  
The device works continuously up to 34 V DC without damage. If the supply voltage is exceeded, the specified characteristics are no longer guaranteed.
- Behavior in the event of undervoltage:  
If the supply voltage falls below the minimum value, the device switches off in a defined manner (status same as for no power supply).

**Electrical connection**

**Degree of protection**

Device	Connection	Climate class	Option <sup>1)</sup>
PTC31B PTP31B	Cable 5 m (16 ft)	IP66/67 NEMA type 4X enclosure	D
PTC31B PTP31B	Cable 10 m (33 ft)	IP66/67 NEMA type 4X enclosure	E
PTC31B PTP31B	Cable 25 m (82 ft)	IP66/67 NEMA type 4X enclosure	F
PTC31B PTP31B	M12 plug	IP65/67 NEMA type 4X enclosure	M
PTC31B PTP31B	Valve plug ISO4400 M16	IP65 NEMA type 4X enclosure	U
PTC31B PTP31B	Valve plug ISO4400 NPT ½	IP65 NEMA type 4X enclosure	V

1) Product Configurator, order code for "Electrical connection"

**Cable specification**

For valve plug: < 1.5 mm<sup>2</sup> (16 AWG) and Ø3.5 to 6.5 mm (0.14 to 0.26 in)

**Residual ripple**

The device operates within the reference accuracy up to ±5 % of the residual ripple of the supply voltage, within the permitted voltage range.

**Influence of power supply**

≤0.005 % of the URL/1 V

**Overvoltage protection**

The device does not contain any special elements to protect against overvoltage ("wire to ground"). Nevertheless the requirements of the applicable EMC standard EN 61000-4-5 (testing voltage 1kV EMC wire/ground) are met.



## Performance characteristics of ceramic process isolating diaphragm

<b>Reference operating conditions</b>	<ul style="list-style-type: none"> <li>▪ As per IEC 60770</li> <li>▪ Ambient temperature <math>T_A</math> = constant, in the range of: +21 to +33 °C (+70 to +91 °F)</li> <li>▪ Humidity <math>\varphi</math> = constant, in the range of 5 to 80 % rH</li> <li>▪ Ambient pressure <math>p_A</math> = constant, in the range of: 860 to 1 060 mbar (12.47 to 15.37 psi)</li> <li>▪ Position of measuring cell = constant, in range: horizontal <math>\pm 1^\circ</math> (see also "Influence of the installation position" section → 20)</li> <li>▪ Zero based span</li> <li>▪ Material of process isolating diaphragm: <math>Al_2O_3</math> (aluminum-oxide ceramic, Ceraphire®)</li> <li>▪ Supply voltage: 24 V DC <math>\pm 3</math> V DC</li> <li>▪ Load: 320 <math>\Omega</math> (at 4 to 20 mA output)</li> </ul>
---------------------------------------	---

<b>Measuring uncertainty for small absolute pressure measuring ranges</b>	<p><b>The smallest extended uncertainty of measurement that can delivered by our standards is:</b></p> <ul style="list-style-type: none"> <li>▪ in range 1 to 30 mbar (0.0145 to 0.435 psi): 0.4 % of reading</li> <li>▪ in range &lt; 1 mbar (0.0145 psi): 1 % of reading.</li> </ul>
---	--

<b>Influence of the installation position</b>	→ 20
---	------

<b>Resolution</b>	<p>Current output: min. 1.6 <math>\mu</math>A</p> <p>Display: can be set (factory setting: presentation of the maximum accuracy of the transmitter)</p>
-------------------	---

**Reference accuracy** The reference accuracy contains the non-linearity [DIN EN 61298-2 3.11] including the pressure hysteresis [DIN EN 61298-23.13] and non-repeatability [DIN EN 61298-2 3.11] in accordance with the limit point method as per [DIN EN 60770].

Device	% of the calibrated span to the maximum turn down		
	Reference accuracy	Non-linearity <sup>1)</sup>	Non-repeatability
PTC31B - standard	$\pm 0.5$	$\pm 0.1$	$\pm 0.1$
PTC31B - platinum	$\pm 0.3$	$\pm 0.1$	$\pm 0.1$

1) The non-linearity for the 40 bar (600 psi) sensor can be up to  $\pm 0.15\%$  of the calibrated span up to the maximum turn down.

Overview of the turn down ranges → 11

### Ordering Information

Description	Option <sup>1)</sup>
Platinum (on request)	D
Standard	G

1) Product Configurator, order code for "Reference accuracy"

<b>Thermal change of the zero output and the output span</b>	<table border="1"> <thead> <tr> <th rowspan="2">Measuring cell</th> <th>-20 to +85 °C (-4 to +185 °F)</th> <th>-40 to -20 °C (-40 to -4 °F) +85 to +100 °C (+185 to +212 °F)</th> </tr> <tr> <th colspan="2">% of URL for TD 1:1</th> </tr> </thead> <tbody> <tr> <td>&lt;1 bar (15 psi)</td> <td>&lt;1</td> <td>&lt;1.2</td> </tr> <tr> <td><math>\geq 1</math> bar (15 psi)</td> <td>&lt;0.8</td> <td>&lt;1</td> </tr> </tbody> </table>	Measuring cell	-20 to +85 °C (-4 to +185 °F)	-40 to -20 °C (-40 to -4 °F) +85 to +100 °C (+185 to +212 °F)	% of URL for TD 1:1		<1 bar (15 psi)	<1	<1.2	$\geq 1$ bar (15 psi)	<0.8	<1
Measuring cell	-20 to +85 °C (-4 to +185 °F)		-40 to -20 °C (-40 to -4 °F) +85 to +100 °C (+185 to +212 °F)									
	% of URL for TD 1:1											
<1 bar (15 psi)	<1	<1.2										
$\geq 1$ bar (15 psi)	<0.8	<1										

<b>Long-term stability</b>	<table border="1"> <thead> <tr> <th>1 year</th> <th>5 years</th> <th>8 years</th> </tr> </thead> <tbody> <tr> <td colspan="3" style="text-align: center;">% of URL</td> </tr> <tr> <td><math>\pm 0.2</math></td> <td><math>\pm 0.4</math></td> <td>In preparation</td> </tr> </tbody> </table>	1 year	5 years	8 years	% of URL			$\pm 0.2$	$\pm 0.4$	In preparation
1 year	5 years	8 years								
% of URL										
$\pm 0.2$	$\pm 0.4$	In preparation								

**Switch-on time**

$\leq 2$  s (For small measuring ranges, pay attention to the thermal compensation effects.)

## Performance characteristics of metallic process isolating diaphragm

**Reference operating conditions**

- As per IEC 60770
- Ambient temperature  $T_A$  = constant, in the range of: +21 to +33 °C (+70 to +91 °F)
- Humidity  $\varphi$  = constant, in the range of 5 to 80 % rH
- Ambient pressure  $p_A$  = constant, in the range of: 860 to 1060 mbar (12.47 to 15.37 psi)
- Position of measuring cell = constant, in range: horizontal  $\pm 1^\circ$  (see also "Influence of the installation position" section → 20)
- Zero based span
- Process isolating diaphragm material: AISI 316L (1.4435)
- Filling oil: NSF-H1 synthetic oil in accordance with FDA 21 CFR 178.3570
- Supply voltage: 24 V DC  $\pm 3$  V DC
- Load: 320  $\Omega$  (at 4 to 20 mA output)

**Measuring uncertainty for small absolute pressure measuring ranges**

- The smallest extended uncertainty of measurement that can delivered by our standards is:**
- in range 1 to 30 mbar (0.0145 to 0.435 psi): 0.4 % of reading
  - in range < 1 mbar (0.0145 psi): 1 % of reading.

**Influence of the installation position**

→ 20

**Resolution**

Current output: min. 1.6  $\mu$ A

Display: can be set (factory setting: presentation of the maximum accuracy of the transmitter)

**Reference accuracy**

The reference accuracy contains the non-linearity [DIN EN 61298-2 3.11] including the pressure hysteresis [DIN EN 61298-23.13] and non-repeatability [DIN EN 61298-2 3.11] in accordance with the limit point method as per [DIN EN 60770].

Device	% of the calibrated span to the maximum turn down		
	Reference accuracy	Non-linearity	Non-repeatability
PTP31B - standard	$\pm 0.5$	$\pm 0.1$	$\pm 0.1$
PTP31B - platinum	$\pm 0.3$	$\pm 0.1$	$\pm 0.1$

Overview of the turn down ranges → 12

*Ordering Information*

Description	Option <sup>1)</sup>
Platinum (on request)	D
Standard	G

1) Product Configurator, order code for "Reference accuracy"

**Thermal change of the zero output and the output span**

Measuring cell	-20 to +85 °C (-4 to +185 °F)	-20 to -40 °C (-4 to -40 °F) +85 to +100 °C (+185 to +212 °F)
	% of the calibrated span for TD 1:1	
<1 bar (15 psi)	<1	<1.2
$\geq 1$ bar (15 psi)	<0.8	<1

**Long-term stability**

1 year	5 years	8 years
% of URL		
$\pm 0.2$	$\pm 0.4$	In preparation

Switch-on time  $\leq 2$  s

## Installation

### Installation conditions

- No moisture may enter the housing when installing or operating the device, or when establishing the electrical connection.
- Point the cable and connector downwards where possible to prevent moisture from entering (e.g. rain or condensation water).

### Influence of the installation position

Any orientation is possible. However, the orientation may cause a zero point shift i.e. the measured value does not show zero when the vessel is empty or partially full.

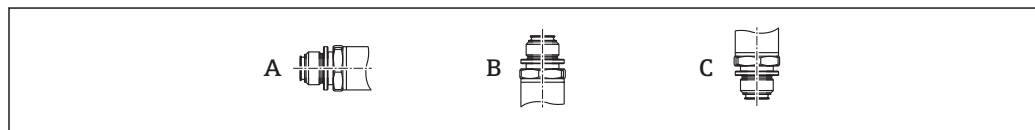

A0024706

Type	Process isolating diaphragm axis is horizontal (A)	Process isolating diaphragm pointing upwards (B)	Process isolating diaphragm pointing downwards (C)
PTP31B	Calibration position, no effect	Up to +4 mbar (+0.058 psi)	Up to -4 mbar (-0.058 psi)
PTC31B < 1 bar (15 psi)	Calibration position, no effect	Up to +0.3 mbar (+0.0044 psi)	Up to -0.3 mbar (-0.0044 psi)
PTC31B $\geq 1$ bar (15 psi)	Calibration position, no effect	Up to +3 mbar (+0.0435 psi)	Up to -3 mbar (-0.0435 psi)



A position-dependent zero shift can be corrected on the device .

### Mounting location

#### Pressure measurement

##### Pressure measurement in gases

Mount the device with shutoff device above the tapping point so that any condensate can flow into the process.

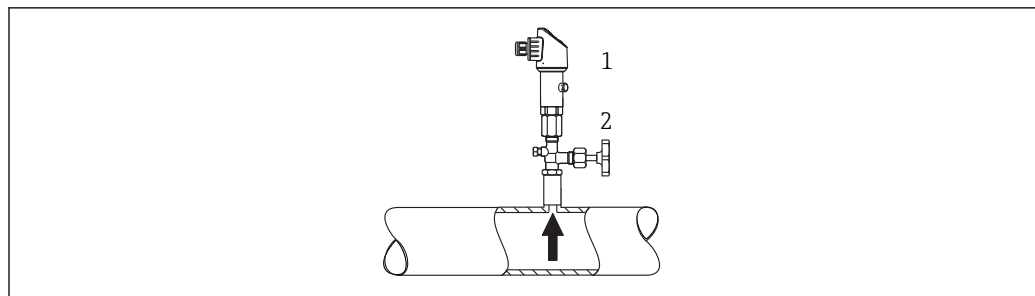

A0025920

- 1 Device
- 2 Shutoff device

##### Pressure measurement in vapors

For pressure measurement in vapors, use a siphon. The siphon reduces the temperature to almost ambient temperature. Preferably mount the device with the shutoff device and siphon below the tapping point.

Advantage:

- defined water column causes only minor/negligible measuring errors and
- only minor/negligible heat effects on the device.

Mounting above the tapping point is also permitted.

Note the max. permitted ambient temperature of the transmitter!

Take the influence of the hydrostatic water column into consideration.

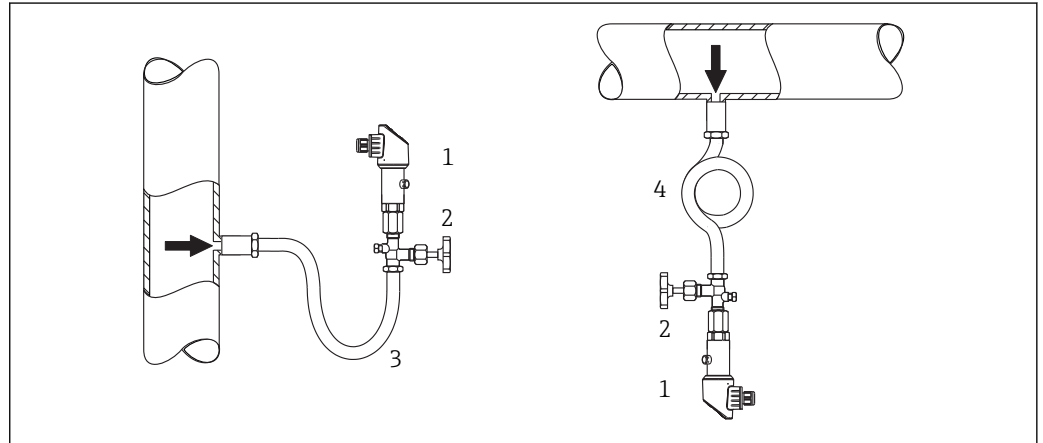

A0025921

- 1 Device
- 2 Shutoff device
- 3 Siphon
- 4 Siphon

#### Pressure measurement in liquids

Mount the device with a shutoff device and siphon below or at the same height as the tapping point.

Advantage:

- defined water column causes only minor/negligible measuring errors and
- air bubbles can be released to the process.

Take the influence of the hydrostatic water column into consideration.

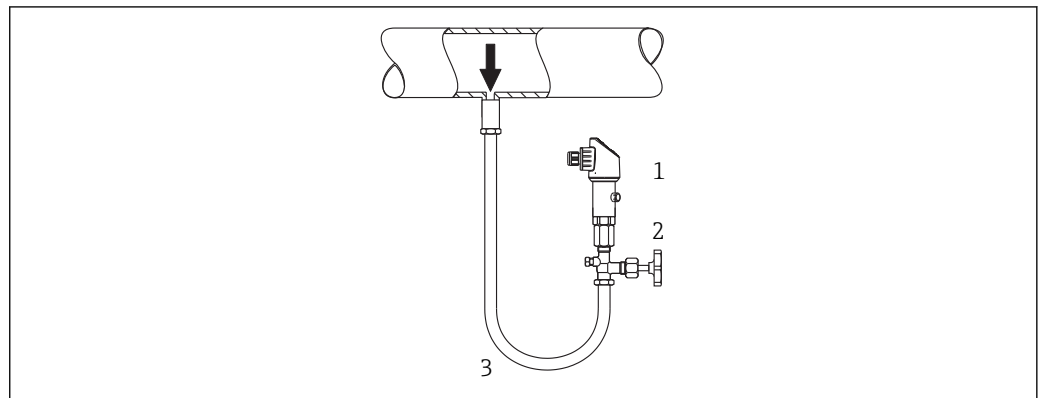

A0025922

- 1 Device
- 2 Shutoff device
- 3 Siphon

#### Level measurement

- Always install the device below the lowest measuring point.
- Do not install the device at the following positions:
  - In the filling curtain
  - In the tank outlet
  - In the suction area of a pump
  - Or at a point in the tank which could be affected by pressure pulses from the agitator.
- Functional testing can be carried out more easily if you mount the device downstream from a shutoff device.

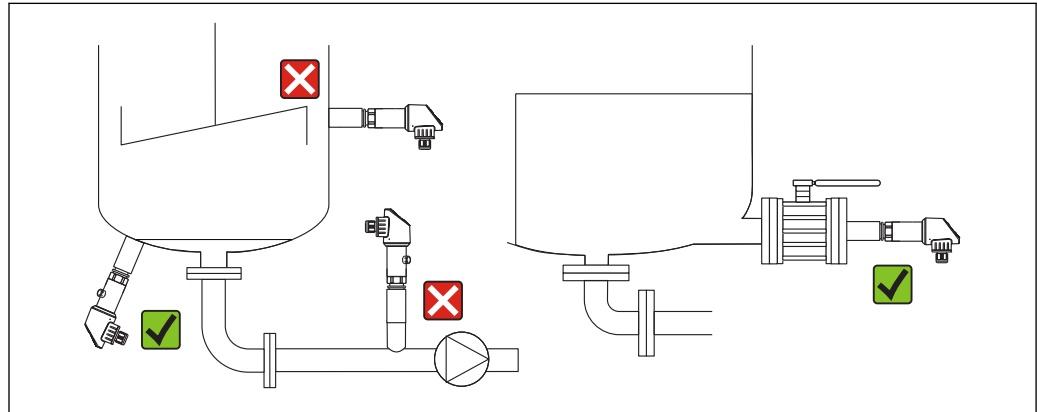

A0025923

### Mounting instructions for oxygen applications

Oxygen and other gases can react explosively to oils, grease and plastics, such that, among other things, the following precautions must be taken:

- All components of the system, such as measuring devices, must be cleaned in accordance with the BAM requirements.
- Dependent on the materials used, a certain maximum temperature and a maximum pressure for oxygen applications must not be exceeded.
- The following table lists devices (devices only, not accessories or enclosed accessories), which are suitable for gaseous oxygen applications.

Device	$p_{\max}$ for oxygen applications	$T_{\max}$ for oxygen applications	Option <sup>1)</sup>
PTC31B	40 bar (600 psi)	-10 to +60 °C (+14 to +140 °F)	HB

1) Product Configurator, order code for "Service"

## Environment

Ambient temperature range	Device	Ambient temperature range <sup>1)</sup>
	PTC31B PTP31B	-20 to +70 °C (-4 to +158 °F) (in the range of the temperature limits with restrictions in optical properties, such as display speed and contrast)

- 1) Exception: the following cable is designed for an operating temperature range of -25 to +70 °C (-13 to +158 °F): Product Configurator order code for "Accessory enclosed", option "RZ".

**Storage temperature range** -40 to +85 °C (-40 to +185 °F)

Climate class	Device	Climate class	Note
	PTC31B PTP31B	Class 3K5	Air temperature: -5 to +45 °C (+23 to +113 °F), relative humidity: 4 to 95 % satisfied according to IEC 721-3-3 (condensation not possible)

Degree of protection	Device	Connection	Climate class	Option <sup>1)</sup>
	PTC31B PTP31B	Cable 5 m (16 ft)	IP66/67 NEMA type 4X enclosure	D
	PTC31B PTP31B	Cable 10 m (33 ft)	IP66/67 NEMA type 4X enclosure	E
	PTC31B PTP31B	Cable 25 m (82 ft)	IP66/67 NEMA type 4X enclosure	F
	PTC31B PTP31B	M12 plug	IP65/67 NEMA type 4X enclosure	M
	PTC31B PTP31B	Valve plug ISO4400 M16	IP65 NEMA type 4X enclosure	U
	PTC31B PTP31B	Valve plug ISO4400 NPT ½	IP65 NEMA type 4X enclosure	V

- 1) Product Configurator, order code for "Electrical connection"

Vibration resistance	Test standard	Vibration resistance
	IEC 60068-2-64:2008	Guaranteed for 5 to 2000Hz: 0.05g <sup>2</sup> /Hz

### Electromagnetic compatibility

- Interference emission as per EN 61326-1 equipment B
- Interference immunity as per EN 61326-1 (industrial environment)
- NAMUR recommendation EMC (NE21)
- Maximum deviation: 1.5% for TD 1:1

For more details, refer to the Declaration of Conformity.

## Process

### Process temperature range for devices with ceramic process isolating diaphragm

Device	Process temperature range
PTC31B	-25 to +100 °C (-13 to +212 °F)

- For saturated steam applications, use a device with a metal process isolating diaphragm, or provide a siphon for temperature isolation when installing.
- Pay attention to the process temperature range of the seal. See also the following table.

Seal	Notes	Process temperature range	Option
FKM	-	-20 to +100 °C (-4 to +212 °F)	A <sup>1)</sup>
FKM	Cleaned for oxygen service	-10 to +60 °C (+14 to +140 °F)	A <sup>1)</sup> and HB <sup>2)</sup>
EPDM 70	-	-25 to +100 °C (-13 to +212 °F)	J <sup>1)</sup>

- 1) Product Configurator, order code for "Seal"
- 2) Product Configurator, order code for "Service"

### Applications with changes in temperature

Frequent extreme changes in temperatures can temporarily cause measuring errors. Temperature compensation takes place after a few minutes. Internal temperature compensation is faster the smaller the change in temperature and the longer the time interval.

For further information please contact your local Endress+Hauser Sales Center.

### Process temperature range for devices with metallic process isolating diaphragm

Device	Process temperature range
PTP31B	-40 to +100 °C (-40 to +212 °F)

### Applications with changes in temperature

Frequent extreme changes in temperatures can temporarily cause measuring errors. Internal temperature compensation is faster the smaller the change in temperature and the longer the time interval.

For further information please contact your local Endress+Hauser Sales Center.

### Pressure specifications

#### WARNING

**The maximum pressure for the measuring device depends on the lowest-rated element with regard to pressure.**

- ▶ For pressure specifications, see the "Measuring range" section and the "Mechanical construction" section.
- ▶ The Pressure Equipment Directive (2014/68/EU) uses the abbreviation "PS". The abbreviation "PS" corresponds to the MWP (maximum working pressure) of the measuring device.
- ▶ MWP (maximum working pressure): The MWP (maximum working pressure) is specified on the nameplate. This value is based on a reference temperature of +20 °C (+68 °F) and may be applied to the device for an unlimited period of time. Observe the temperature dependency of the MWP.
- ▶ OPL (over pressure limit): The test pressure corresponds to the over pressure limit of the sensor and may only be applied temporarily to ensure that the measurement is within the specifications and no permanent damage develops. In the case of sensor range and process connections where the over pressure limit (OPL) of the process connection is smaller than the nominal value of the sensor, the device is set at the factory, at the very maximum, to the OPL value of the process connection. If you want to use the entire sensor range, select a process connection with a higher OPL value.
- ▶ Devices with ceramic process isolating diaphragm: avoid steam hammering! Steam hammering can cause zero point drifts. Recommendation: Residue (water droplets or condensation) may remain on the process isolating diaphragm following CIP cleaning and can result in local steam hammering the next time steam cleaning takes place. In practice, drying the process isolating diaphragm (e.g. by blowing) has proved to prevent steam hammering.



## Mechanical construction

### Design, dimensions

### Device height

The device height is calculated from

- the height of the electrical connection
- the height of the housing and
- the height of the individual process connection.

The individual heights of the components are listed in the following sections. To calculate the device height simply add up the individual heights of the components. Where applicable also take into consideration the installation distance (space that is used to install the device). You can use the following table for this purpose:

Section	Page	Height	Example
Electrical connection	→ 25	(A)	
Housing height	→ 26	(B)	
Process connection height	→ 27 → 30	(C)	
Installation distance	-	(D)	

### Electrical connection

<p><b>A</b></p>	<p><b>B</b></p>	<p><b>C</b></p>
Engineering unit mm (in)		

Position	Description	Material	Weight kg (lbs)	Option <sup>1)</sup>
A	M12 plug IP65/67 (Additional dimensions → 43)	Housing cap made of plastic	0.012 (0.03)	M Plug connector with cable can be ordered as an accessory → 43
B	Cable 5 m (16 ft)	PUR (UL94V0)	0.280 (0.62)	D
B	Cable 10 m (33 ft)	PUR (UL94V0)	0.570 (1.26)	E
B	Cable 25 m (82 ft)	PUR (UL94V0)	1.400 (3.09)	F
C	M16 valve plug	Plastic PPSU	0.060 (0.14)	U
C	NPT ½ valve plug	Plastic PPSU	0.060 (0.14)	V

1) Product Configurator, order code for "Electrical connection"

Housing

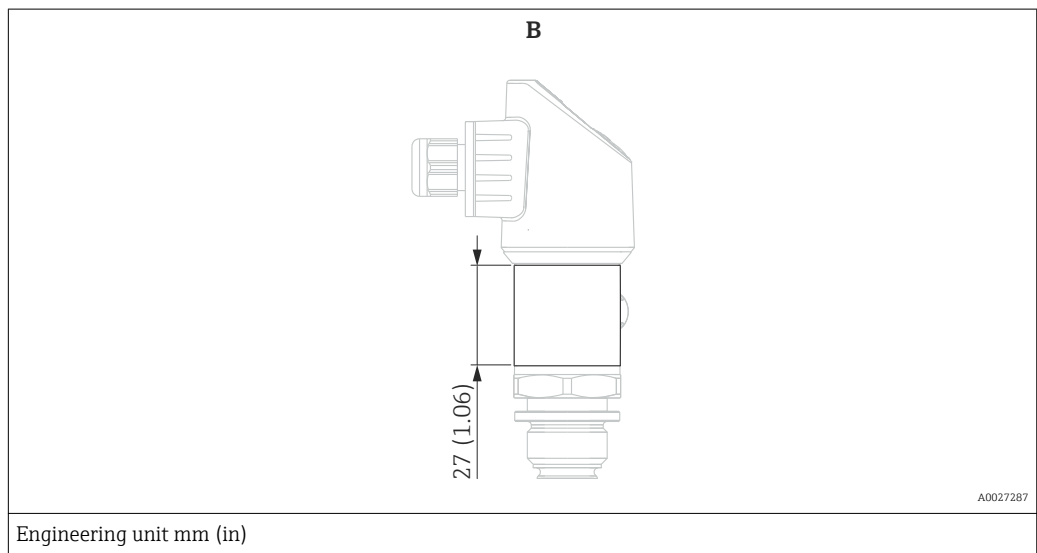
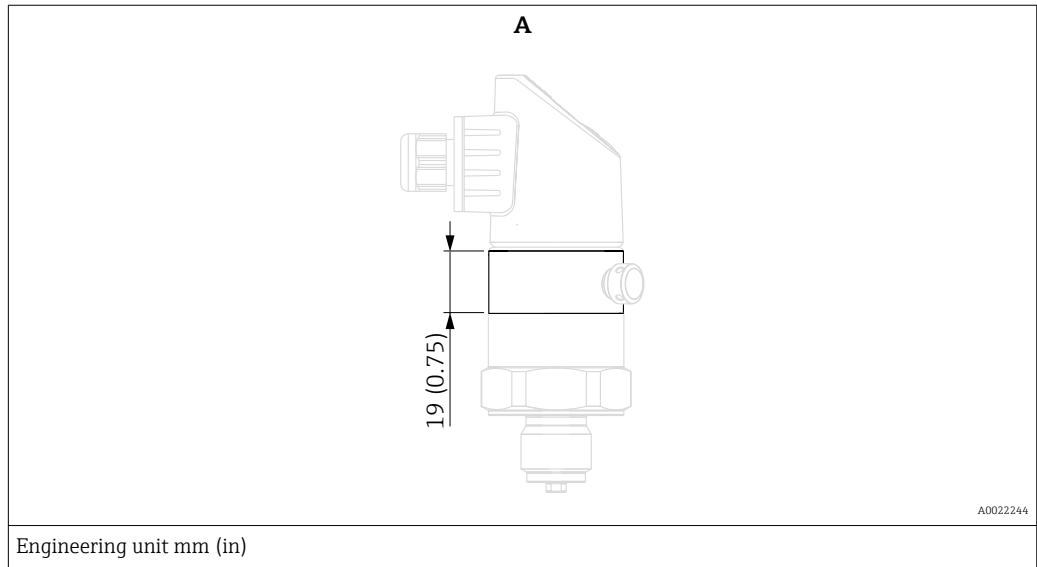

Item	Device	Material	Weight kg (lbs)
A	PTC31B	Stainless steel 316L	0.150 (0.33)
B	PTP31B	Stainless steel 316L	0.090 (0.20)

Process connections with internal, ceramic process isolating diaphragm

Thread ISO 228 G

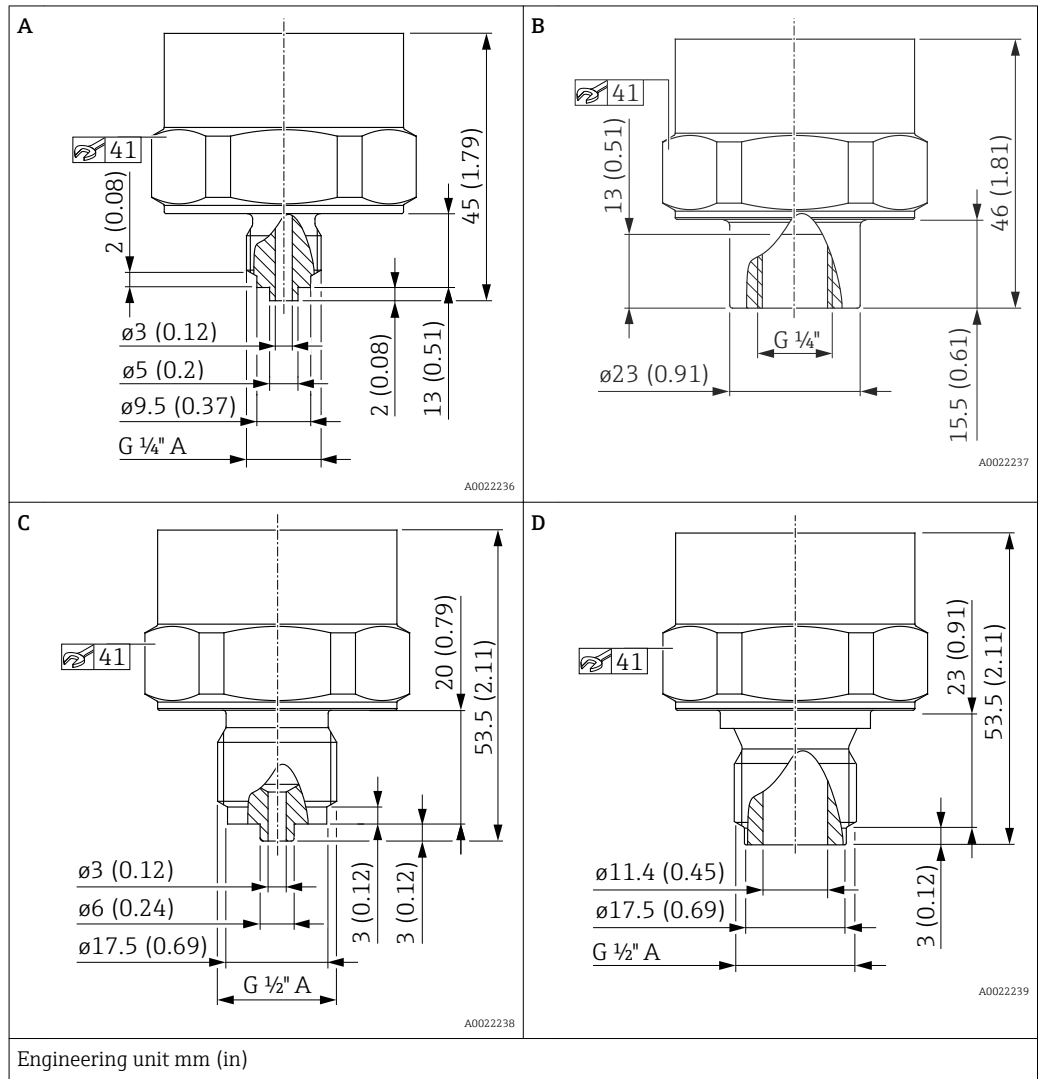

Device	Item	Description	Material	Weight	Option <sup>1)</sup>
				kg (lbs)	
PTC31B	A	Thread ISO 228 G 1/4" A, EN 837	316L	0.160 (0.35)	WTJ
PTC31B	B	Thread ISO 228 G 1/4" (female)	316L	0.180 (0.40)	WAJ
PTC31B	C	Thread ISO 228 G 1/2" A, EN 837	316L	0.180 (0.40)	WBJ
PTC31B	D	Thread ISO 228 G 1/2" A, bore 11.4 mm (0.45 in)	316L	0.180 (0.40)	WWJ

1) Product Configurator, order code for "Process connection"

Process connections with internal, ceramic process isolating diaphragm

Thread ASME

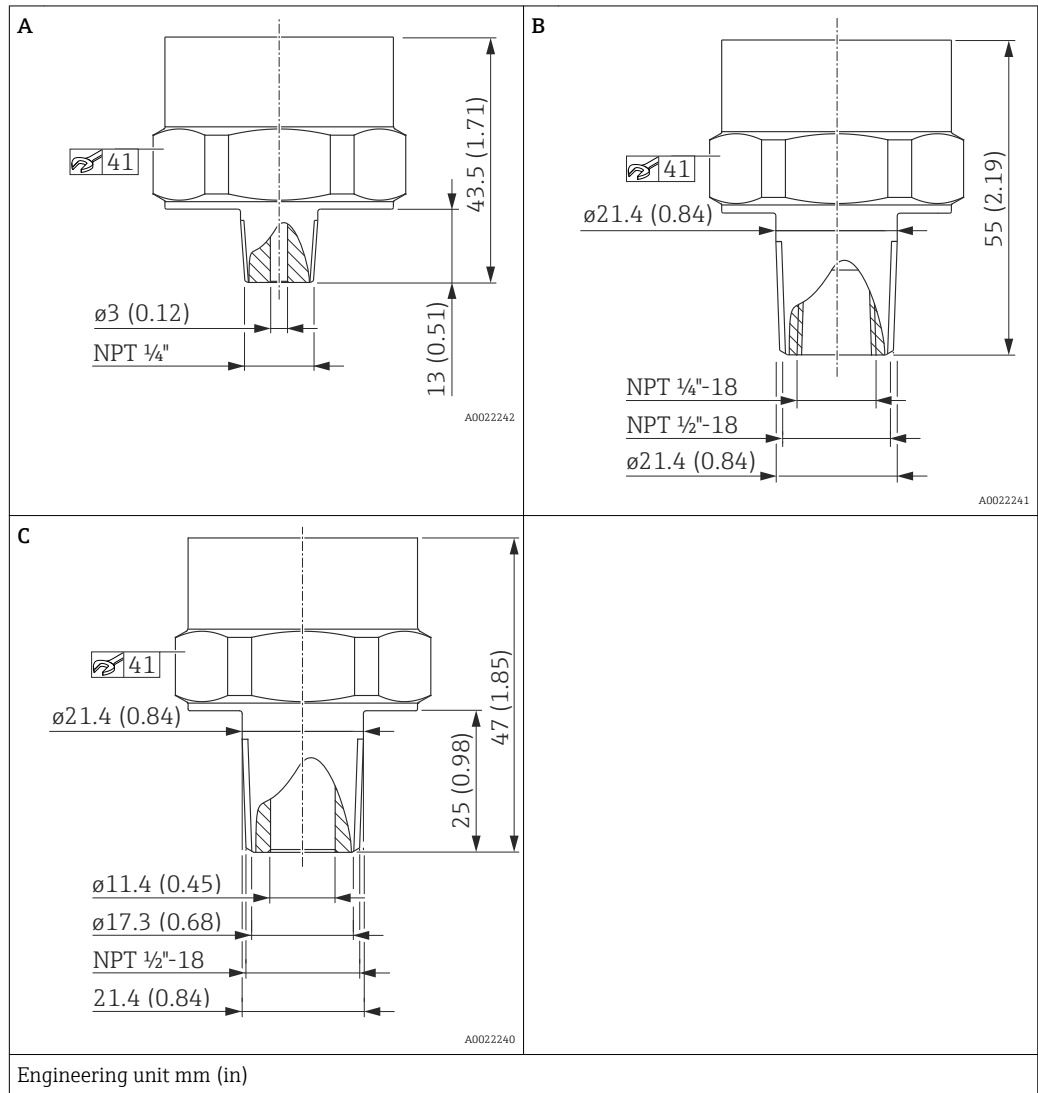

Device	Item	Description	Material	Weight	Approval	Option <sup>1)</sup>
				kg (lbs)		
PTC31B	A	ASME 1/4" MNPT, bore3 mm (0.12 in)	316L	0.160 (0.35)	CRN	VUJ
PTC31B	B	ASME 1/2" MNPT, 1/4" FNPT (female)	316L	0.190 (0.42)	CRN	VXJ
PTC31B	C	ASME 1/2" MNPT, bore11.4 mm (0.45 in)	316L	0.190 (0.42)	CRN	VWJ

1) Product Configurator, order code for "Process connection"

Process connections with internal, ceramic process isolating diaphragm

Thread DIN13

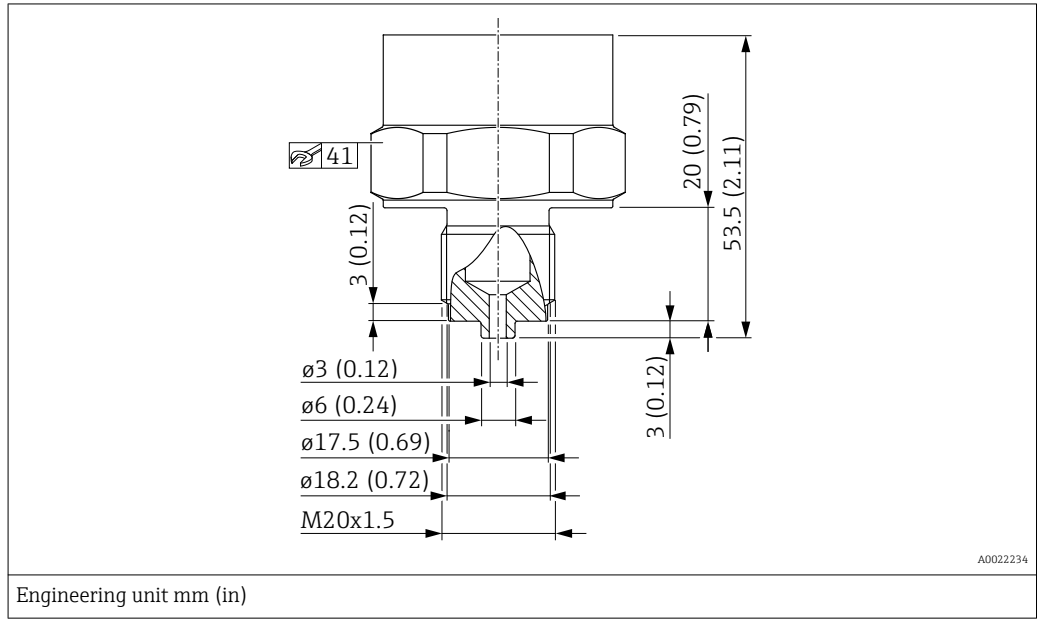

Device	Description	Material	Weight	Option <sup>1)</sup>
			kg (lbs)	
PTC31B	DIN 13 M20 x 1.5, EN 837, bore 3 mm (0.12 in)	316L	0.180 (0.40)	X4J

1) Product Configurator, order code for "Process connection"

Process connections with internal, ceramic process isolating diaphragm

Thread JIS B0203

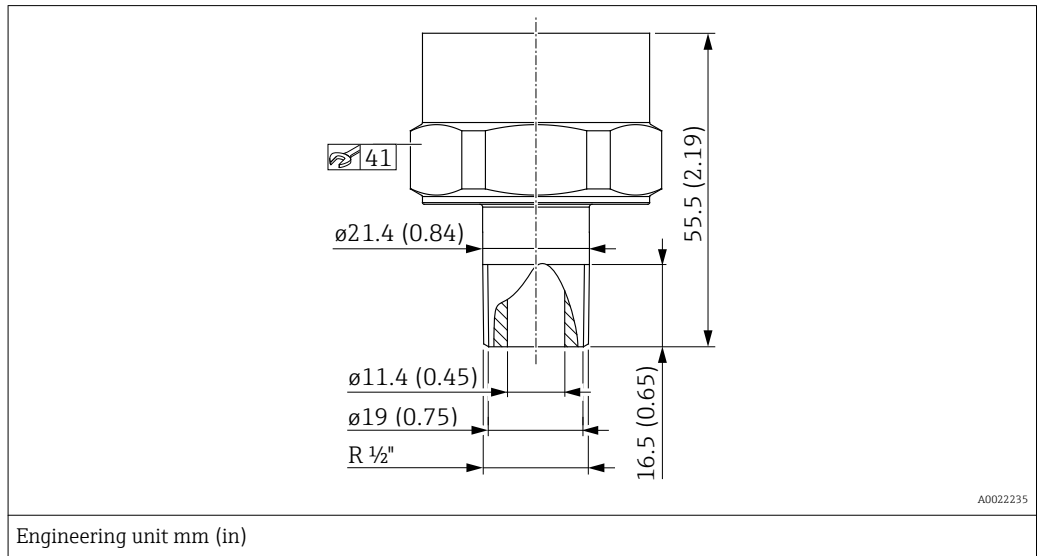

Device	Description	Material	Weight	Option <sup>1)</sup>
			kg (lbs)	
PTC31B	JIS B0203 R 1/2 (male)	316L	0.180 (0.40)	ZJJ

1) Product Configurator, order code for "Process connection"

Process connections with internal, metal process isolating diaphragm

Thread ISO 228 G

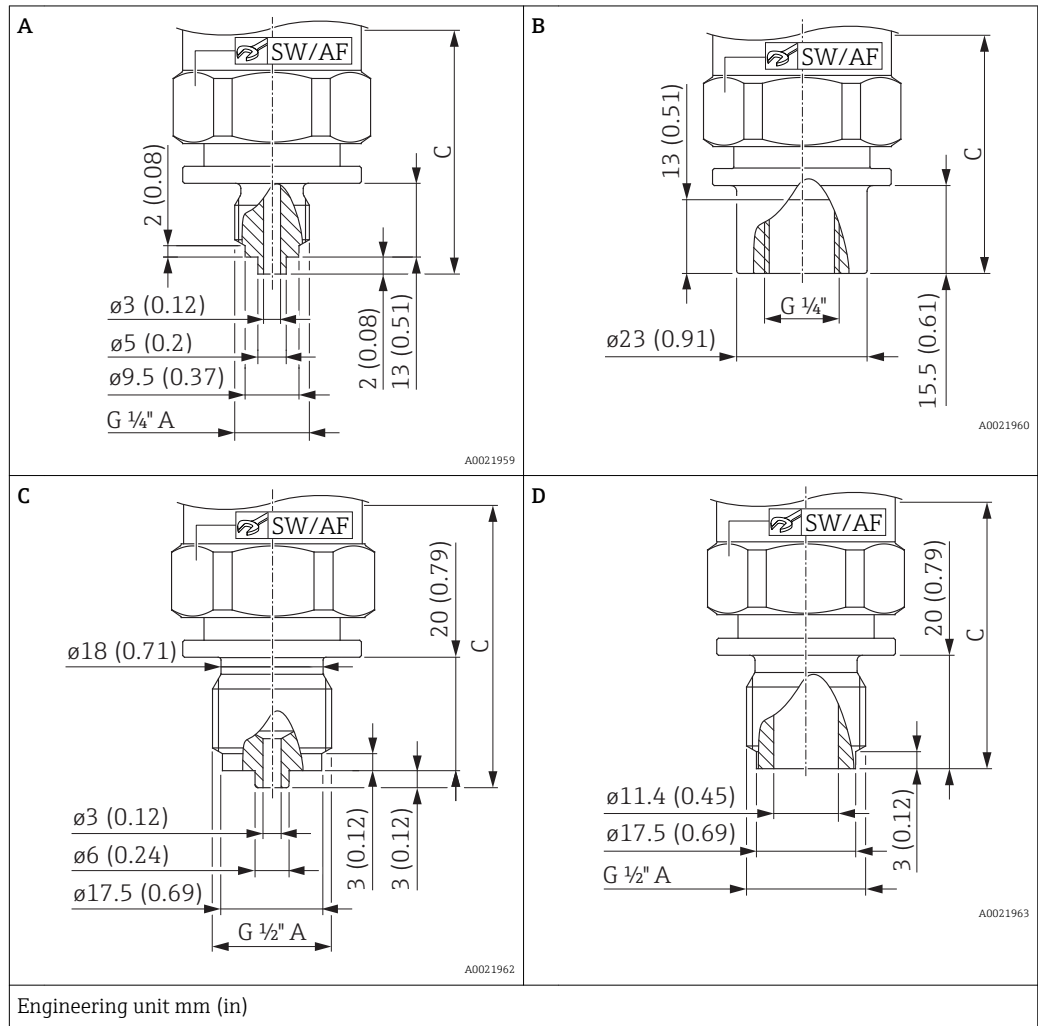

Position	Device	Description	Material	Nominal value to 100 bar (1 500 psi)			Nominal value 400 bar (6 000 psi)			Option <sup>1)</sup>
				Weight	Height C	SW/AF	Weight	Height C	SW/AF	
				kg (lbs)			kg (lbs)			
A	PTP31B	Thread ISO 228 G 1/4" A, EN 837	316L	0.200 (0.44)	57 (2.24)	32	0.240 (0.53)	69 (2.72)	27	WTJ
B	PTP31B	Thread ISO 228 G 1/4" (female)	316L	0.220 (0.49)	57 (2.24)	32	0.260 (0.57)	69 (2.72)	27	WAJ
C	PTP31B	Thread ISO 228 G 1/2" A, EN 837	316L	0.220 (0.49)	65 (2.56)	32	0.270 (0.60)	77 (3.03)	27	WBJ
D	PTP31B	Thread ISO 228 G 1/2" A, bore 11.4 mm (0.45 in)	316L	0.220 (0.49)	62 (2.44)	32	0.260 (0.57)	74 (2.91)	27	WWJ

1) Product Configurator, order code for "Process connection"

Process connections with internal, metal process isolating diaphragm

Thread ASME

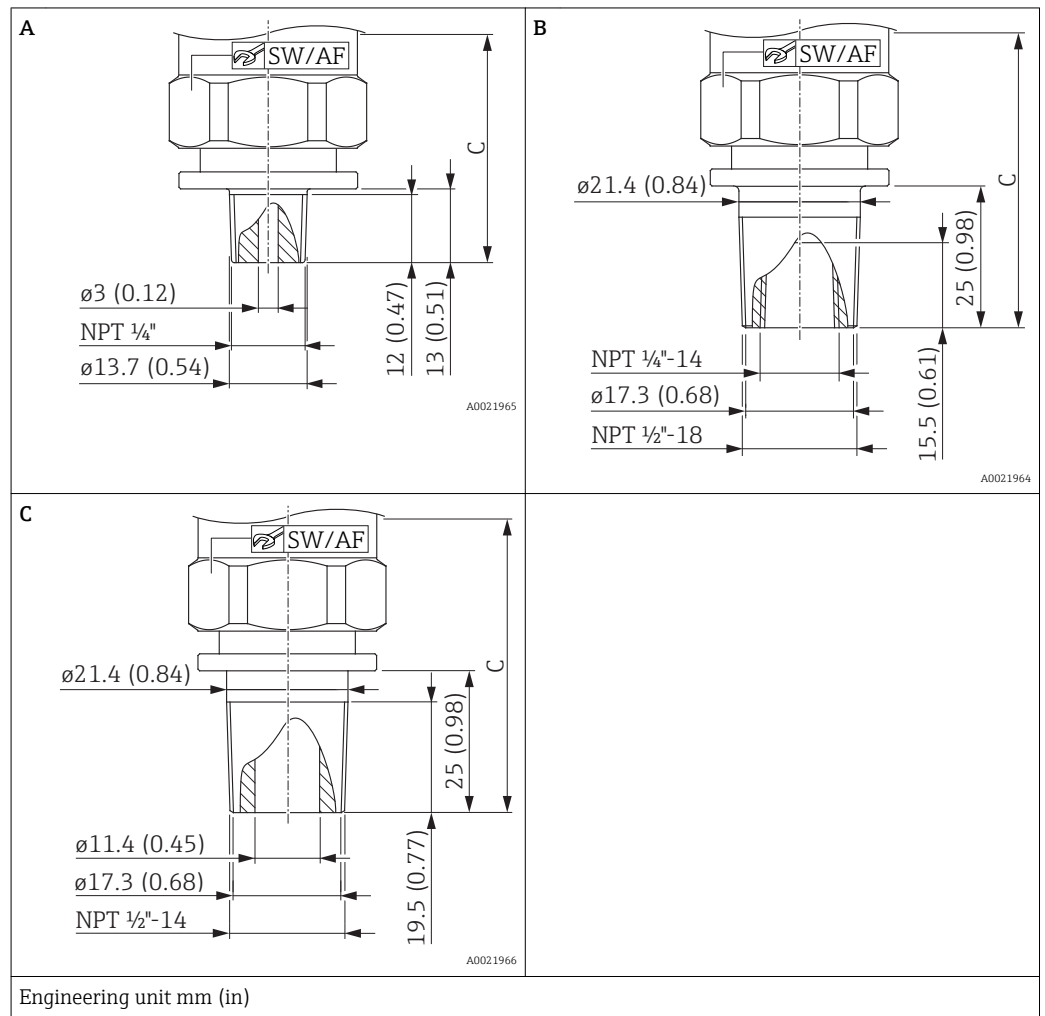

Position	Device	Description	Material	Nominal value to 100 bar (1 500 psi)			Nominal value 400 bar (6 000 psi)			Approval	Option <sup>1)</sup>
				Weight kg (lbs)	Height C	SW/ AF	Weight kg (lbs)	Height C	SW/ AF		
A	PTP31B	ASME 1/4" MNPT, bore 3 mm (0.12 in)	316L	0.200 (0.44)	55 (2.17)	32	0.240 (0.53)	67 (2.64)	27	CRN	VUJ
B	PTP31B	ASME 1/2" MNPT, 1/4" FNPT (female)	316L	0.230 (0.51)	67 (2.64)	32	0.260 (0.57)	79 (3.11)	27	CRN	VXJ
C	PTP31B	ASME 1/2" MNPT, bore 11.4 mm (0.45 in)	316L	0.230 (0.51)	67 (2.67)	32	0.270 (0.60)	79 (3.11)	27	CRN	VWJ

1) Product Configurator, order code for "Process connection"

Process connections with internal, metal process isolating diaphragm

Thread DIN13

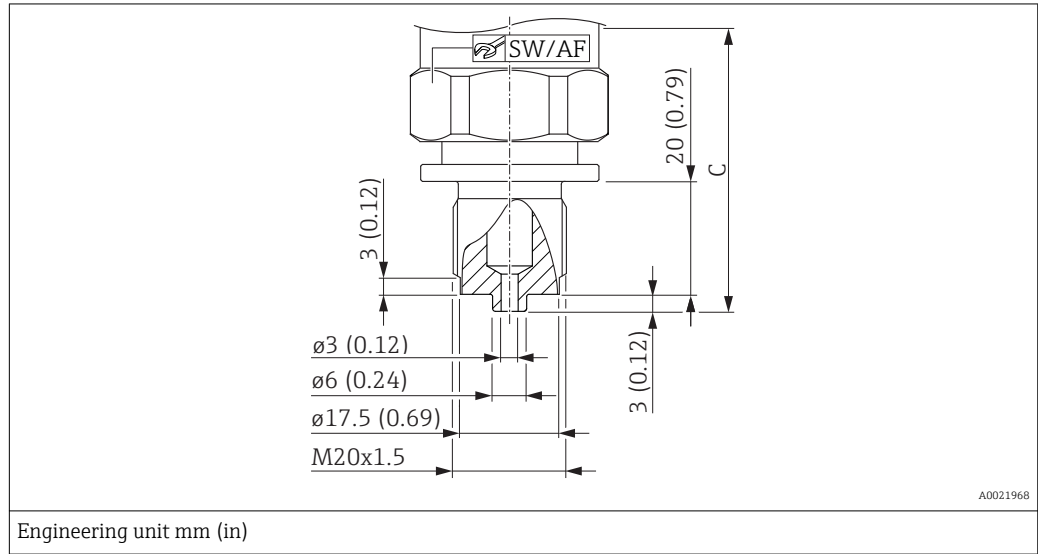

Description	Device	Material	Nominal value to 100 bar (1 500 psi)			Nominal value 400 bar (6 000 psi)			Option <sup>1)</sup>
			Weight	Height C	SW/AF	Weight	Height C	SW/AF	
			kg (lbs)			kg (lbs)			
DIN 13 M20 x 1.5, EN 837, bore 3 mm (0.12 in)	PTP31B	316L	0.220 (0.49)	65 (2.56)	32	0.260 (0.57)	77 (3.03)	27	X4J

1) Product Configurator, order code for "Process connection"

Process connections with internal, metal process isolating diaphragm

Thread JIS B0203

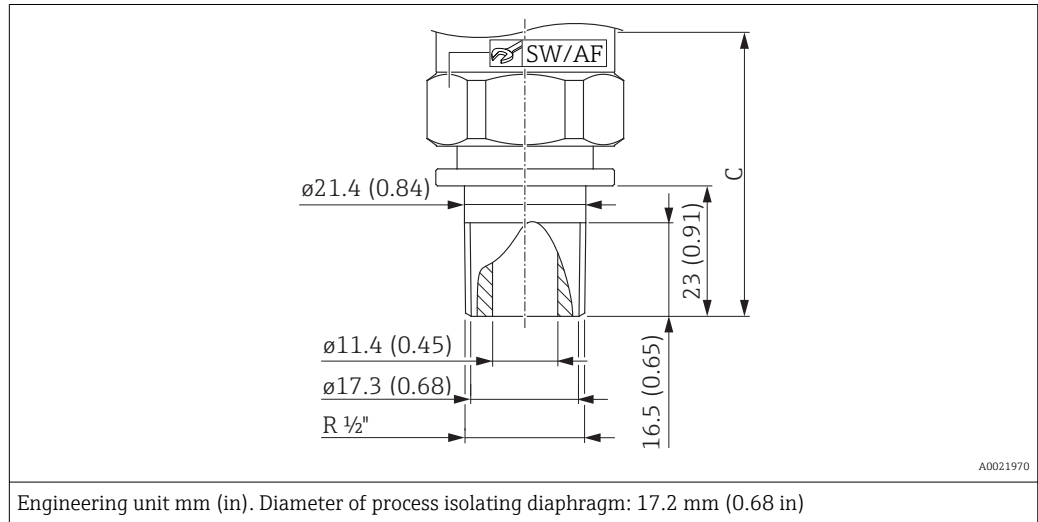

Description	Device	Material	Nominal value to 100 bar (1 500 psi)			Nominal value 400 bar (6 000 psi)			Option <sup>1)</sup>
			Weight	Height C	SW/AF	Weight	Height C	SW/AF	
			kg (lbs)			kg (lbs)			
JIS B0203 R 1/2" (male)	PTP31B	316L	0.230 (0.51)	65 (2.56)	32	0.260 (0.57)	77 (3.03)	27	ZJJ

1) Product Configurator, order code for "Process connection"



Process connections with flush-mounted, metal process isolating diaphragm

Thread ISO 228 G

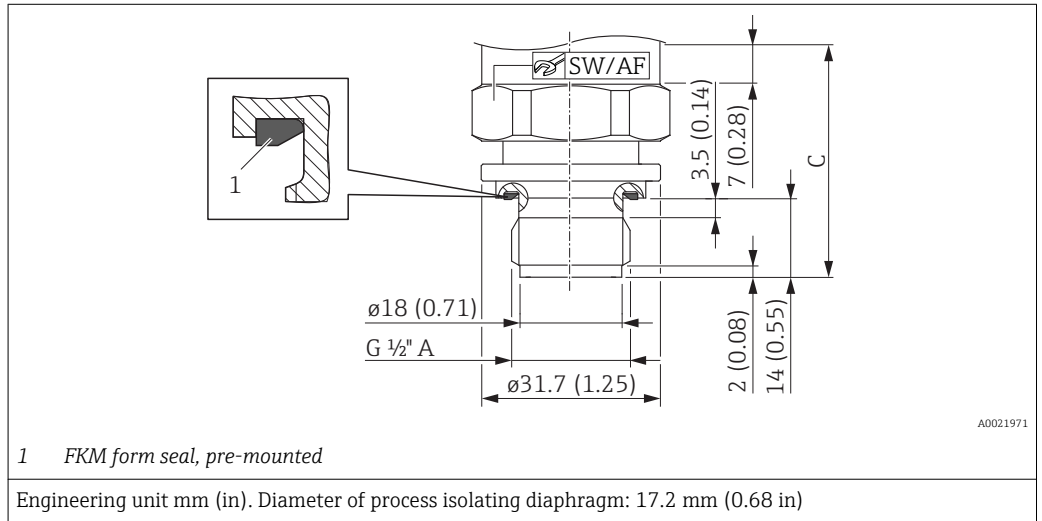

Device	Description	Material	Nominal value to 100 bar (1 500 psi)			Nominal value 400 bar (6 000 psi)			Option <sup>1)</sup>
			Weight	Height C	SW/AF	Weight	Height C	SW/AF	
			kg (lbs)			kg (lbs)			
PTP31B	Thread ISO 228 G 1/2" A DIN3852	316L	0.140 (0.31)	41 (1.61)	32	0.120 (0.26)	35 (1.38)	32	WJJ

1) Product Configurator, order code for "Process connection"

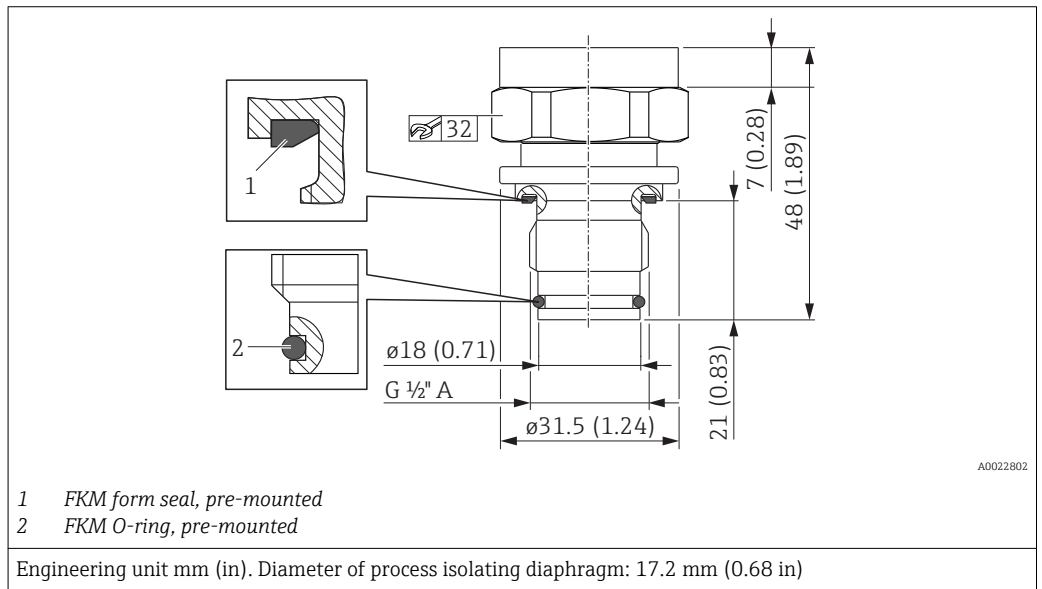

Device <sup>1)</sup>	Description	Material	Weight	Option <sup>2)</sup>
			kg (lbs)	
PTP31B	Thread ISO 228 G 1/2" A O-ring seal, flush-mounted	316L	0.150 (0.33)	WUJ

1) Suitable for weld-in adapter 52002643 and 52010172  
2) Product Configurator, order code for "Process connection"

**Materials in contact with process****NOTICE**

- ▶ Device components in contact with the process are listed in the "Mechanical construction" and "Ordering information" sections.

**TSE Certificate of Suitability**

The following applies to all device components in contact with the process:

- They do not contain any materials derived from animals.
- No additives or operating materials derived from animals are used in production or processing.

**Process connections**

Endress+Hauser supplies a threaded connection made of stainless steel in accordance with AISI 316L (DIN/ EN material number 1.4404 or 1.4435). With regard to their stability-temperature property, the materials 1.4404 and 1.4435 are grouped together under 13E0 in EN 1092-1: 2001 Tab. 18. The chemical composition of the two materials can be identical.

**Process isolating diaphragm**

Description	Material
Ceramic process isolating diaphragm	Al <sub>2</sub> O <sub>3</sub> aluminum-oxide ceramic, Ceraphire® FDA, ultrapure 99.9 % (see also <a href="http://www.endress.com/ceraphire">www.endress.com/ceraphire</a> ) The US Food & Drug Administration (FDA) has no objections to the use of ceramics made from aluminum oxide as a surface material in contact with foodstuffs. This declaration is based on the FDA certificates of our ceramic suppliers.
Metal process isolating diaphragm	AISI 316L (DIN/EN material number 1.4435)

**Seals**

See the specific process connection.

**Materials not in contact with process**     **Housing**

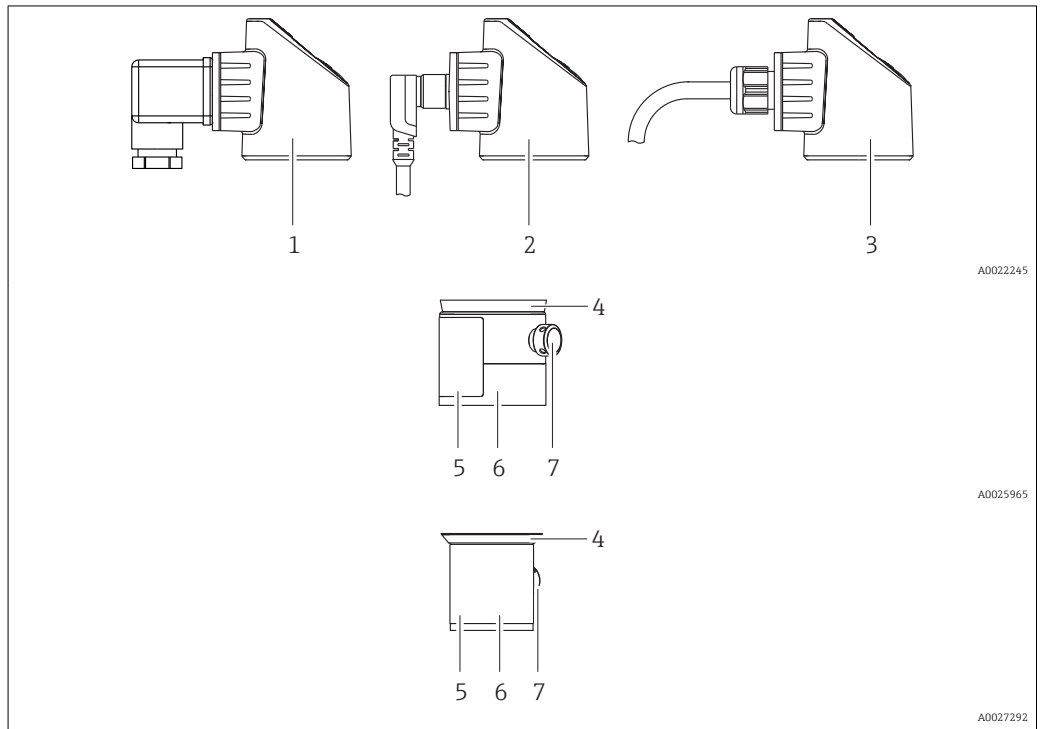

Item number	Component part	Material
1	Housing with valve plug connection	<ul style="list-style-type: none"> <li>▪ Seal: NBR</li> <li>▪ Plug: PA</li> <li>▪ Screw: V2A</li> <li>▪ Adapter plate: PBT/PC</li> <li>▪ Housing: PBT/PC</li> </ul>
2	Housing prepared for M12 plug connection	<ul style="list-style-type: none"> <li>▪ Adapter plate: PBT/PC</li> <li>▪ For other materials, see the "Accessories" section</li> <li>▪ Housing: PBT/PC</li> </ul>
3	Housing with cable connection	<ul style="list-style-type: none"> <li>▪ Pressure screw: PVDF</li> <li>▪ Seal: TPE-V</li> <li>▪ Cable: PUR (UL 94 V0)</li> <li>▪ Adapter plate: PBT/PC</li> <li>▪ Housing: PBT/PC</li> </ul>
4	Design element	PBT/PC
5	Nameplates	Plastic foil (attached to housing) or directly lasered onto the housing
6	Housing	316L (1.4404)
7	Pressure compensation element	PBT/PC

**Filling oil**

Device	Filling oil
PTP31B	NSF-H1 synthetic oil in accordance with FDA 21 CFR 178.3570

**Cleaning**

Device	Description	Option <sup>1)</sup>
PTC31B PTP31B	Cleaned from oil+grease	HA
PTC31B	Cleaned for oxygen service	HB

1) Product Configurator, order code for "Service"

## Operability

### Operation with local display

#### Overview

A 1-line liquid crystal display (LCD) is used for display and operation. The local display shows measured values, fault messages and information messages and therefore supports the user through each operating step.

During measuring operation, the display shows measured values, fault messages and notice messages. In addition, it is possible to switch to menu mode via the operating keys.

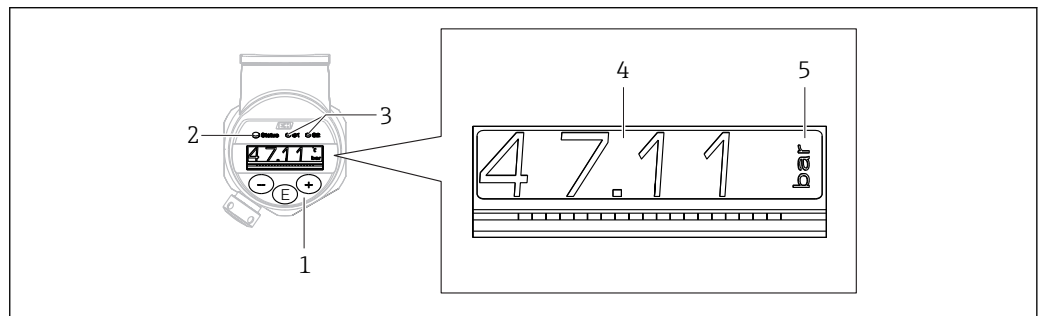

A0022121

- 1 Operating keys
- 2 Status LED
- 3 Switch output LEDs
- 4 Measured value
- 5 Unit

The second switch output is not used for the device version with current output.

#### Functions:

- 4-digit measured value display and decimal point
- Simple and complete menu guidance due to breakdown of parameters into several levels and groups
- Possibility to configure the display in accordance with individual wishes and requirements
- Comprehensive diagnostic functions (fault and warning message, peak-hold indicators, etc.)
- Quick and safe commissioning
- The device also signals the status via LEDs.

**Functions of switch output**

The switch output can be used for two-point control (hysteresis) or for monitoring a process pressure range (window function).

**Hysteresis**

Sample explanation. Device with two switch outputs.

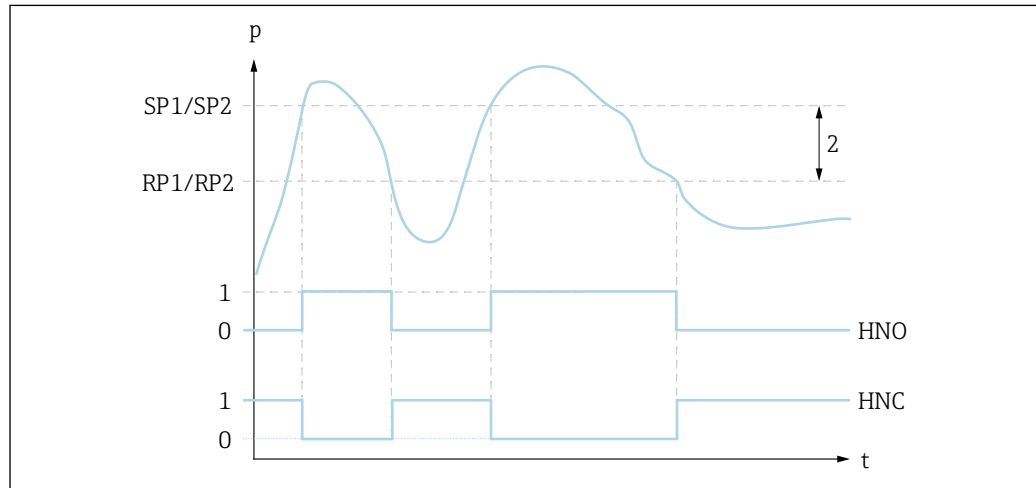

1 SP1/SP2: switch point 1/2; RP1/RP2: switch-back point 1/2

0 0-signal. Output open in quiescent state.

1 1-signal. Output closed in quiescent state.

2 Hysteresis

HNO Closing

HNC NC contact

*Description*

When the set switch point "SP1/SP2" is reached (with increasing pressure), an electrical signal change takes place at the switch output.

When the set switchback point "RP1/RP2" is reached (with decreasing pressure), an electrical signal change takes place at the switch output.

The difference between the value of the switch point "SP1/SP2" and the switchback point "RP1/RP2" is known as the hysteresis.

### Window function

Sample explanation. Device with two switch outputs.

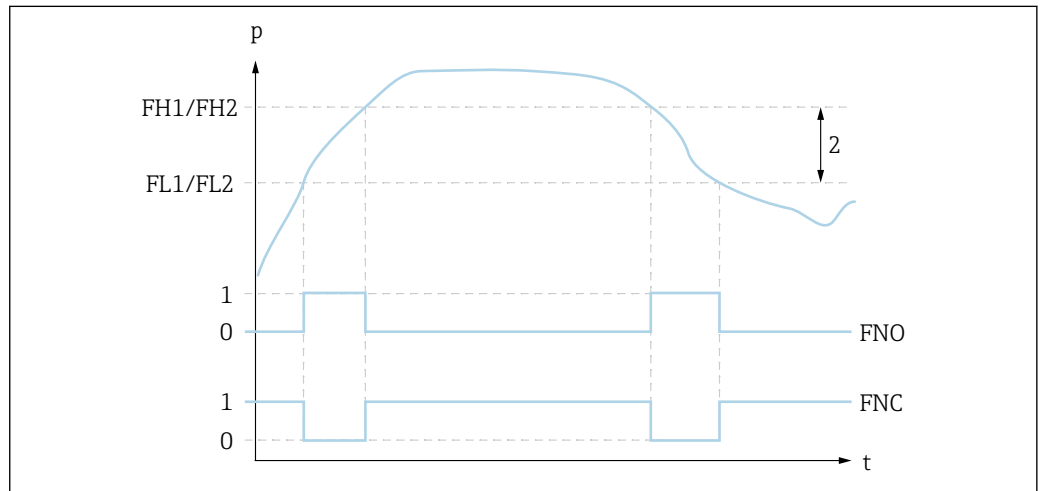

2 FH1/FH2: upper value of pressure window; FL1/FL2: lower value of pressure window

0 0-signal. Output open in quiescent state.

1 1-signal. Output closed in quiescent state.

2 Pressure window (difference between the value of the high window "FH1/FH2" and the low window "FL1/FL2")

FNO Closing

FNC NC contact

#### Description

When the lower value of the pressure window "FL1/FL2" is reached (with increasing or decreasing pressure), an electrical signal change takes place at the switch output.

When the upper value of the pressure window "FH1/FH2" is reached (with increasing or decreasing pressure), an electrical signal change takes place at the switch output.

The difference between the upper value of the pressure window "FH1/FH2" and the lower value of the pressure window "FL1/FL2" is known as the pressure window.

## Certificates and approvals

**CE mark** The device meets the legal requirements of the relevant EC directives. Endress+Hauser confirms that the device has been successfully tested by applying the CE mark.

**RoHS** The measuring system complies with the substance restrictions of the Restriction on Hazardous Substances Directive 2011/65/EU (RoHS 2).

**RCM-Tick marking** The supplied product or measuring system meets the ACMA (Australian Communications and Media Authority) requirements for network integrity, interoperability, performance characteristics as well as health and safety regulations. Here, especially the regulatory arrangements for electromagnetic compatibility are met. The products are labelled with the RCM- Tick marking on the name plate.



A0029561

### Pressure Equipment Directive 2014/68/EU (PED)

#### Pressure equipment with allowable pressure $\leq 200$ bar (2 900 psi)

Pressure equipment (with a maximum allowable pressure  $PS \leq 200$  bar (2 900 psi)) can be classified as pressure accessories in accordance with Pressure Equipment Directive 2014/68/EU. If the maximum allowable pressure is  $\leq 200$  bar (2 900 psi) and the pressurized volume of the pressure equipment is  $\leq 0.1$  l, the pressure equipment is subject to the Pressure Equipment Directive (cf. Pressure Equipment Directive 2014/68/EU, Article 4, point 3). The Pressure Equipment Directive only requires that the pressure equipment shall be designed and manufactured in accordance with the "sound engineering practice of a Member State".

*Reasons:*

- Pressure Equipment Directive (PED) 2014/68/EU Article 4, point 3
- Pressure equipment directive 2014/68/EU, Commission's Working Group "Pressure", Guideline A-05 + A-06

*Note:*

A partial examination shall be performed for pressure instruments that are part of safety equipment for the protection of a pipe or vessel from exceeding allowable limits (safety accessory in accordance with Pressure Equipment Directive 2014/68/EU, Article 2, point 4).

#### Pressure equipment with allowable pressure $> 200$ bar (2 900 psi)

Pressure equipment designated for application in every process fluid having a pressurized volume of  $<0.1$  l and a max. allowable pressure  $PS > 200$  bar (2 900 psi) shall satisfy the essential safety requirements set out in Annex I of the Pressure Equipment Directive 2014/68/EU. According to Article 13 pressure equipment shall be classified by category in accordance with Annex II. The conformity assessment of the pressure equipment shall be determined by the category I under consideration of the above-mentioned low pressurized volume. These devices shall be provided with CE marking.

*Reasons:*

- Pressure Equipment Directive 2014/68/EU, Article 13, Annex II
- Pressure equipment directive 2014/68/EU, Commission's Working Group "Pressure", Guideline A-05

*Note:*

A partial examination shall be performed for pressure instruments that are part of safety equipment for the protection of a pipe or vessel from exceeding allowable limits (safety accessory in accordance with Pressure Equipment Directive 2014/68/EU, Article 2, point 4).

*The following also applies:*

PTP31B with threaded connection and internal process isolating diaphragm  $PN > 200$  :



Suitable for stable gases in group 1, category I, module A

**Other standards and guidelines**

The applicable European guidelines and standards can be found in the relevant EU Declarations of Conformity. The following were also applied:

**DIN EN 60770 (IEC 60770):**

Transmitters for use in industrial process control systems Part 1: Methods for performance evaluation

Methods for evaluating the performance of transmitters for control and regulation in industrial process control systems.

**DIN 16086:**

Electrical pressure measuring instruments, pressure sensors, pressure transmitters, pressure measuring instruments, concepts, specifications on data sheets

Procedure for writing specifications in data sheets for electrical pressure measuring instruments, pressure sensors and pressure transmitters.

**EN 61326-X:**

EMC product family standard for electrical equipment for measurement, control and laboratory use.

**EN 60529:**

Degrees of protection provided by enclosures (IP code)

**NAMUR - User association of automation technology in process industries.**

NE21 - Electromagnetic Compatibility (EMC) of Industrial Process and Laboratory Control Equipment.

NE43 - Standardization of the Signal Level for the Failure Information of Digital Transmitters.

NE44 - Standardization of Status Indicators on PCT Instruments with the Help of Light Emitting Diodes

NE53 - Software of Field Devices and Signal-processing Devices with Digital Electronics

NE107 - Self-monitoring and Diagnosis of Field Devices

**VDMA 24574-1:2008-04**

Fluid technology terms, menu navigation and electrical connection for fluid sensors, Part 1: Pressure switches

**CRN approval**

A CRN approval is available for some device versions. A CRN-approved process connection with a CSA approval must be ordered for a CRN-approved device. The CRN-approved devices are assigned the registration number 0F18141.5C.

Ordering information: Product Configurator, order code for "Process connection" (the CRN process connections are indicated appropriately in the "Mechanical construction" section.)

**Calibration unit**

Description	Option <sup>1)</sup>
Sensor range; %	A
Sensor range; mbar/bar	B
Sensor range; kPa/MPa	C
Sensor range; psi	F
Switch 1; see additional spec.	S
Switch 1 + 2; see additional spec.	T
Switch, analog output; see additional spec.	U

1) Product Configurator, order code for "Calibration; unit"

**Calibration**

Description	Option <sup>1)</sup>
3-point certificate of calibration	F3

1) Product Configurator order code for "Calibration"

**Inspection certificates**

Device	Description	Option <sup>1)</sup>
PTC31B PTP31B	3.1 Material documentation, wetted metal parts, EN10204-3.1 inspection certificate	JA

1) Product Configurator, order code for "Test, Certificate"

## Ordering information

Detailed ordering information is available from the following sources:

- In the Product Configurator on the Endress+Hauser website: [www.endress.com](http://www.endress.com) -> Click "Corporate" -> Select your country -> Click "Products" -> Select the product using the filters and search field -> Open product page -> The "Configure" button to the right of the product image opens the Product Configurator.
- From your Endress+Hauser Sales Center: [www.addresses.endress.com](http://www.addresses.endress.com)

### Product Configurator - the tool for individual product configuration

- Up-to-the-minute configuration data
  - Depending on the device: Direct input of measuring point-specific information such as measuring range or operating language
  - Automatic verification of exclusion criteria
  - Automatic creation of the order code and its breakdown in PDF or Excel output format
  - Ability to order directly in the Endress+Hauser Online Shop

**Scope of delivery**

- Measuring device
- Optional accessories
- Brief Operating Instructions
- Certificates

## Accessories

**Weld-in adapter** Various weld-in adapters are available for installation in vessels or pipes.

Device	Description	Option <sup>1)</sup>	Order number
PTP31B	Weld-in adapter G½, 316L	QA	52002643
PTP31B	Weld-in adapter G½, 316L 3.1 EN10204-3.1 material, inspection certificate	QB	52010172
PTP31B	Weld-in tool adapter G½, brass	QC	52005082

1) Product Configurator, order code for "Enclosed accessories"

If installed horizontally and weld-in adapters with a leakage hole are used, ensure that the leakage hole is pointing down. This allows leaks to be detected as quickly as possible.

### M12 plug connectors

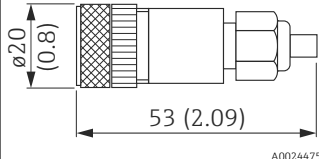
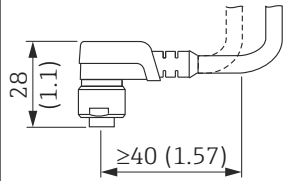
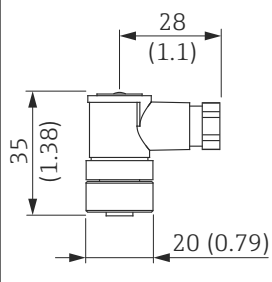
Connector	Degree of protection	Material	Option <sup>1)</sup>	Order number
M12 (self-terminated connection at M12 plug) 	IP67	<ul style="list-style-type: none"> <li>■ Union nut: Cu Sn/Ni</li> <li>■ Body: PBT</li> <li>■ Seal: NBR</li> </ul>	R1	52006263
M12 90 degrees with 5m (16 ft) cable 	IP67	<ul style="list-style-type: none"> <li>■ Union nut: GD Zn/Ni</li> <li>■ Body: PUR</li> <li>■ Cable: PVC</li> </ul>	RZ	52010285
M12 90 degrees (self-terminated connection at M12 plug) 	IP67	<ul style="list-style-type: none"> <li>■ Union nut: GD Zn/Ni</li> <li>■ Body: PBT</li> <li>■ Seal: NBR</li> </ul>	RM	71114212

1) Product Configurator, order code for "Enclosed accessories"

## Documentation

---

<b>Field of Activities</b>	Pressure measurement, powerful instruments for process pressure, differential pressure, level and flow: FA00004P/00/EN
<b>Technical Information</b>	<ul style="list-style-type: none"><li>■ TI00241F/00/EN: EMC test procedures</li><li>■ TI00426F/00/EN: Weld-in adapters, process adapters and flanges (overview)</li></ul>
<b>Operating Instructions</b>	BA01270P/00/EN
<b>Brief Operating Instructions</b>	KA01163P/00/EN

---



[www.addresses.endress.com](http://www.addresses.endress.com)

---