

Technical Information

Proline Fieldcheck

Flow simulation system

Verification of calibration and simulation of flow measuring systems



Application

- Functional test and simulation of all Proline flowmeters from Endress+Hauser, without removing the devices from the piping.
- Visualization (HART) and simulation of dynamic procedures in the piping, i.e. presentation of flow curves of a filling/bottling machine's filling valves.
- Checking alarm systems: simulation of faults, such as pipe blockage seized pumps.
- Periodic checking of devices and device components within the framework of the "Preventive Maintenance" programs.
- Simple documentation of all tests as part of inspection equipment monitoring, using "FieldCare" software. Includes date, provided on paper or in a file.

Features and benefits

The tried and tested Fieldcheck **tester and simulator** enables the following:

- Checking the function and verifying calibration without having to remove the device from the pipe
- Simulation of different flow behavior in the process.
- Examining and optimizing parts of a process, safety systems or an entire device without any flow being present
- Simultaneously examining the linearity of signal outputs (current, frequency)

In addition, **Fieldcheck devices** offer the following:

- Proven Endress+Hauser operating concept with "Touch Control"
- Clear display with graphics capabilities
- Extremely easy-to-use due to the option of various operating languages
- Test results can be read, analyzed, printed, archived and exported using FieldCare software

Scope of delivery, function and system design

Scope of delivery

The equipment supplied with Fieldcheck comprises the following components:

- The Fieldcheck flow simulator with battery pack (1)
- Connecting cable for the service interface (4)
- Connecting cable for the Simubox (5)
- 2 × connecting cables for the current and frequency output (3)
- Line adapter (6)
- Softcase (2)
- RS 232 connecting cable for connecting Fieldcheck to a computer (9-pin COM interface). Not shown.
- Operating Instructions (not shown).

The Simuboxes for the respective flow measuring systems, the sensor test boxes and the system-specific sensor adapters are available via separate order numbers.



Measuring principle**Simulation**

Fieldcheck simulates a measurement signal, that is sent directly to the measuring amplifier in place of the actual sensor signal. In the Fieldcheck display, the flow measured value output by the measuring device and the value that is fed in by the simulator are displayed.

Simulating process states without real flow makes it possible, e.g. for time-critical commissioning, to test under "operating conditions" in a simple, cost-effective manner:

- Simulation of different flow rates in the process
- Simulation of failures (pipe blockage, seized pumps)
- Simulation of exceeding/undershooting limit values during operation (checking alarm systems)
- Checking downstream signal chains (operation of valves or control loops)
- Simulation of dynamic procedures in the piping, e.g. flow curves in filling/bottling machines

Verification

During verification, a measuring device is checked for the following characteristic values:

- Functionality and deviation in the flow measurement.
- Deviation in the current and frequency outputs if these outputs are available in the measuring device.
The displayed deviation is independent of the flow rate determined by the measuring device.

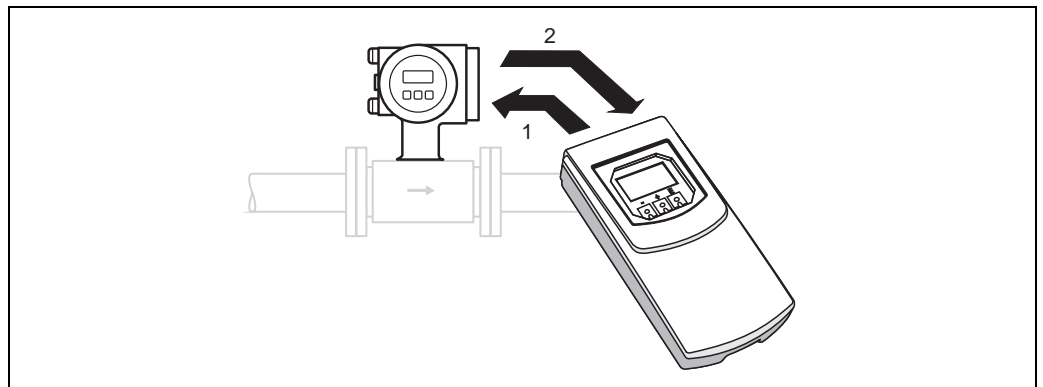

1 Simulation signal provided by Fieldcheck

2 Measured value measured by the measuring device



Note!

Data bus outputs such as FOUNDATION Fieldbus or PROFIBUS cannot be directly checked by Fieldcheck.

Measuring system

The Fieldcheck flow simulation system consists of the following components:

- The Fieldcheck flow simulator itself
- The Simubox for correct connection to measuring device in question

Fieldcheck

The Fieldcheck flow simulator generates the flow simulation signal and processes the measured values sent back by the transmitter.

Simubox

The Simubox ensures that the Fieldcheck simulation signal is correctly converted (Coriolis, electromagnetic, vortex meter, ultrasonic, thermal). There is an appropriate Simubox for each measuring principle.

Sensor test box

Changes in the measuring behavior of Promag and Promass flow sensors can be verified using Fieldcheck and the sensor test box.

Example for Promag flow sensors: buildup on the measuring electrode (deposits) change the measurement result. Comparisons with previous measurements (trending) on the same device indicate a change in the measuring behavior. Results of this type could then indicate the need to clean the measuring electrodes.

Configuration and service software

FieldCare

The future integration of the "ToF Tool - Fieldtool Package" into the new FDT-based "FieldCare" plant asset management tool from Endress+Hauser opens up completely new prospects for configuration, operation and maintenance! Unique about FieldCare is that all standard commercial devices can be supported with it - regardless of the manufacturer!

Fieldcheck

For administration and analysis of verification results from the "Fieldcheck" tester/simulator:

- Read in, evaluate, archive and manage test results.
- Create and print out test results as certificates (e.g. for authorities).
- Export test results to other Windows programs.
- Display test results in graphical or tabular form.
- Call up and list verification or test results that are spaced out over time, e.g. for maintenance planning (History function).

Input

Measured variable	<ul style="list-style-type: none">■ Current input■ Frequency input
Measuring range	<ul style="list-style-type: none">■ Current input: 0 to 25 mA■ Frequency input: 0 to 15000 Hz
Galvanic isolation	Current and frequency inputs are galvanically isolated from each other. Both are isolated from the ground.

Power supply

Electrical connections	Input for power unit <ul style="list-style-type: none">■ 100 to 240 V AC (47 to 63 Hz) primary■ 12 V DC (2.5 A) secondary
Supply voltage	12 V DC; internal battery 7.2 V; 3800 mAh Operating time: 4 to 6 hours
Charging current	Max. 2 A (350 mA, constant, for simultaneous operation)

Performance characteristics

Reference operating conditions	+22 °C ±2K
Max. measured error at the outputs	<ul style="list-style-type: none">■ Measuring devices with electromagnetic flow measuring system (Promag 10, 50, 53, 55): ±0.2% of the full scale value voltage (0.150 to 20 mV)■ Measuring devices with Coriolis mass flow measuring systems (Promass 40, 80, 83, 84): ±0.2 % of the full scale value phase difference
Max. measured error at the inputs	<ul style="list-style-type: none">■ Current input: ±5 µA (0 to 25 mA)■ Frequency input: <0.5 Hz (0 to 15 kHz)

Operating conditions (Environment)

Ambient temperature range	0 to 60 °C
Electromagnetic compatibility (EMC)	In accordance with IEC/EN 61326 and NAMUR Recommendation NE 21

Mechanical construction

Design, dimensions (length × width × height)	<ul style="list-style-type: none"> ■ Fieldcheck: 270 × 130 × 60 mm ■ Simubox (without cable) <ul style="list-style-type: none"> – 120 × 60 × 30 mm (for Promag 10, 50, 53, 55, Prowirl 72, 73) – 150 × 80 × 30 mm (for Promass 40, 80, 83, 84 Prosonic Flow 90, 91, 93 t-mass 65, Sensor Test Box (STB)) ■ Softcase: 400 × 180 × 300 mm
Weight	1.6 kg

Human interface

Display elements	Liquid crystal display: illuminated, adjustable contrast setting for displaying different measured value and status variables
Operating elements	Local operation with three optical keys (⊖, ⊕, ☐)
Computer interface	FieldCare <ul style="list-style-type: none"> ■ Permanent storage of data ■ Printing of certificates ■ Updating Fieldcheck software

Certificates and approvals

CE mark	The measuring system complies with the statutory requirements of the EC Directives. Endress+Hauser confirms successful testing of the device by affixing the CE mark.
Other standards and guidelines	<ul style="list-style-type: none"> ■ EN 60529 Degrees of protection through housing (IP code) ■ EN 61010-1 Protection Measures for Electrical Equipment for Measurement, Control, Regulation and Laboratory Procedures ■ IEC/EN 61326 "Emission in accordance with requirements for Class A equipment." Electromagnetic compatibility (EMC requirements)

Ordering information

Your Endress + Hauser service organization will provide information on ordering and further details on the order code.

Accessories

Various accessories can be supplied for Fieldcheck and they can be ordered separately from Endress+Hauser. Your Endress + Hauser service organization can provide detailed information on the accessory of your choice.

Device-specific accessories

Accessory	Description	Order number
Plug-in power supply unit 85 to 260 VAC	Power unit for charging the battery and for operating Fieldcheck at the mains	50095659
Car adapter 12 VDC	Adapter for connecting to the car battery	50095660
NiMH AccuPack	Additional battery	50095661
Carrier bag	Practical storage bag	50095662
Connecting cable for Simubox to Fieldcheck	For connecting the Simubox to Fieldcheck	50095663
Connecting cable for Fieldcheck/Proline measuring device	For connecting Fieldcheck to the internal service interface of the flowmeter	50097100
Current/frequency measuring cable for Fieldcheck	For connecting Fieldcheck to the current or frequency output of the flowmeter	50095664
Connecting cable for Fieldcheck FieldCare	For connecting Fieldcheck to a personal computer with the FieldCare operating software	50098800

Measuring principle-specific accessories

Accessory	Description	Order number
Simubox MID Promag 10, 50, 53, 55 for Fieldcheck	Serves communication between Fieldcheck and electromagnetic flowmeters	50097102
Simubox Coriolis Promass 40, 80, 83, 84 for Fieldcheck	Serves communication between Fieldcheck and Coriolis mass flowmeters	50097101
Simubox Vortex Prowirl 72, 73 for Fieldcheck	Serves communication between Fieldcheck and vortex flowmeters.	50097105
Simubox thermal t-mass 65 for Fieldcheck	Serves communication between Fieldcheck and thermal mass flowmeters	71023099
Simubox Ultrasonic Prosonic Flow 90, 93 for Fieldcheck	Serves communication between Fieldcheck and ultrasonic flowmeters	50097104
Sensor test box for Fieldcheck, Promag and Promass sensors	Serves to check electrical parameters at the sensors of Promag and Promass measuring devices	71042324
MID adapter for sensor test box	Serves to connect the test box to a sensor for Promag 10, 50, 53, 55 measuring devices	71042326
Coriolis adapter for sensor test box	Serves to connect the test box to a sensor for Promass 40, 80, 83, 84 measuring devices	71042329
PSONIC93 wall housing connection plate set	Serves to connect Fieldcheck to Prosonic Flow 93 Ex-d field housing	50099257
Prosonic Flow test block	Serves to carry out the sensor test on Prosonic Flow 90, 93	50093274

Service-specific accessories

Accessory	Description	Order number
FieldCare	FieldCare is Endress+Hauser's FDT-based plant asset management tool. It offers a wide variety of functionalities, from basic device configuration to solutions for monitoring status. FieldCare enables you to configure, operate and monitor your plant.	Refer to product page on the Endress+Hauser Web site www.endress.com

Documentation

- Flow measuring technology (FA005D/06)
- Operating Instructions (BA067D/06)

Registered trademarks

HART®

Registered trademark of the HART Communication Foundation, Austin, USA

PROFIBUS®

Registered trademark of the PROFIBUS User Organization, Karlsruhe, Germany

FOUNDATION™ Fieldbus

Registered trademark of the Fieldbus FOUNDATION, Austin, USA

Fieldcheck®

Registered trademark of Endress+Hauser Flowtec AG, Reinach, Switzerland

FieldCare®

Registered trademark of Endress+Hauser Process Solutions AG, Reinach, Switzerland

Instruments International

Endress+Hauser
Instruments International AG
Kaegenstrasse 2
4153 Reinach
Switzerland

Tel. +41 61 715 81 00
Fax +41 61 715 25 00
www.endress.com
info@ii.endress.com

Endress+Hauser 
People for Process Automation