



Level



Pressure



Flow



Temperature



Liquid
Analysis



Registration



Systems
Components



Services



Solutions

Special Documentation

Weld-in adapter G 1", G 3/4"

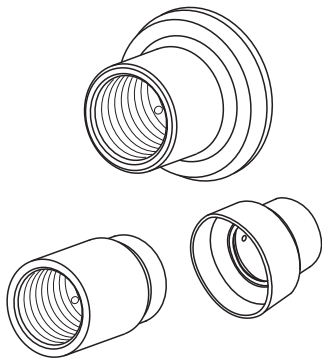

de - Einschweißadapter

en - Weld-in adapter

fr - Adaptateur à souder

es - Adaptador para soldar



it - Adattatore saldato

nl - Inlasadapter

SD00352F/00/A6/01.12
71161872

Endress+Hauser 
People for Process Automation

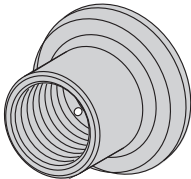
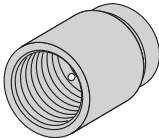
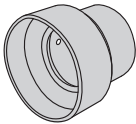
Lieferumfang/Scope of delivery/Étendue de la livraison/Volumen de suministro/Volume di forniture/omvang van de levering

	A G 1", d=60	B G ¾", d=55	C G ¾", d=50	D G ¾", d=29	E G 1", d=53
	316L (1.4435)				
					
	52001051 52011896 *	52001052 52011897 *	52018765 *	52028295 *	71093129 *
 VMQ	ø28.17 x 3.53 (1.11 x 0.14)	ø21.89 x 2.62 (0.86 x 0.1)	ø14.9 x 2.7 (0.59 x 0.10)		ø28.17 x 3.53 (1.11 x 0.14)
 316L (1.4435)	-	-	ø23.7 x 6 (0.93 x 0.24)		-

mm (in)

* mit Abnahmeprüfzeugnis 3.1 / with inspection certificate 3.1 / avec certificat de réception 3.1 /
con certificado de inspección 3.1 / con certificato di collaudo 3.1 / met inspectie-certificaat 3.1

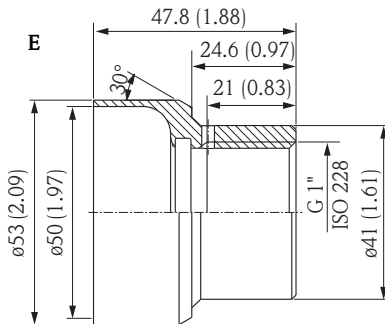
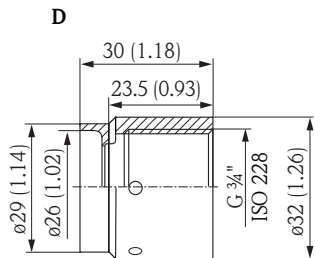
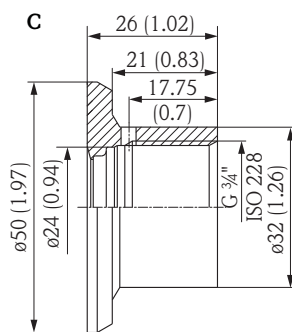
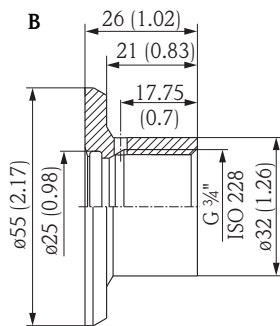
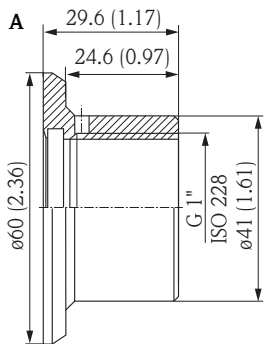

mm (in)

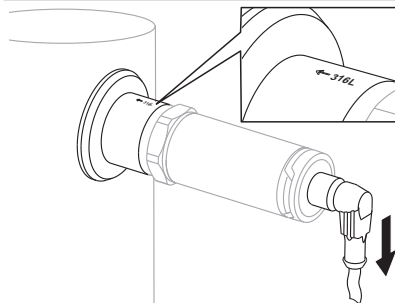
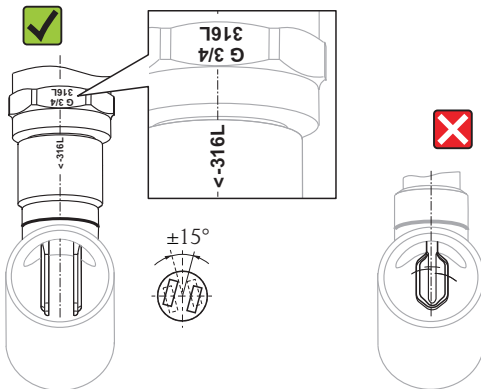
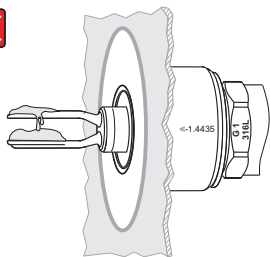
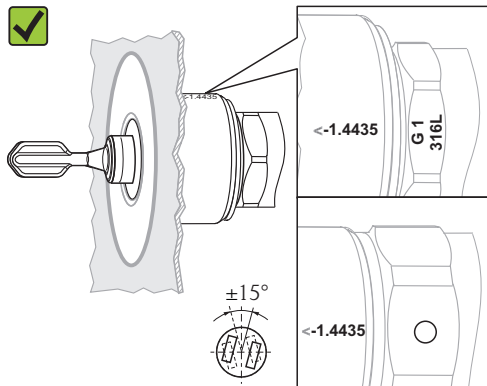

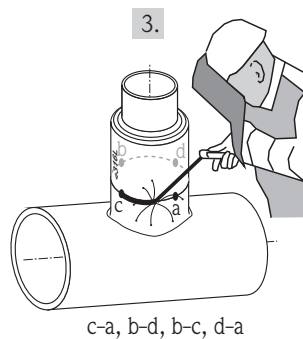
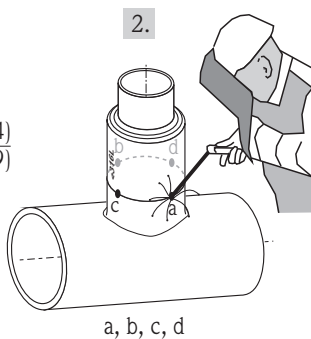
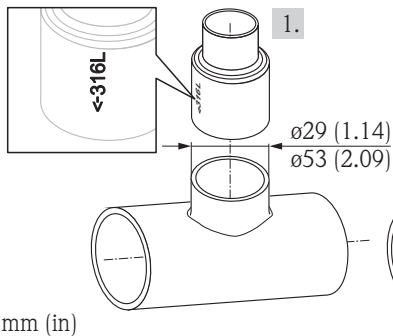
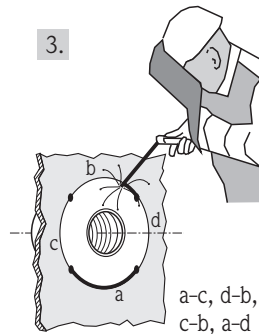
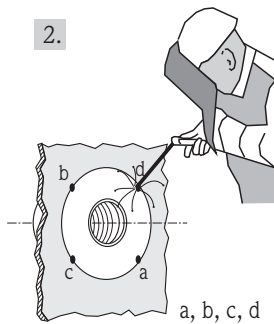
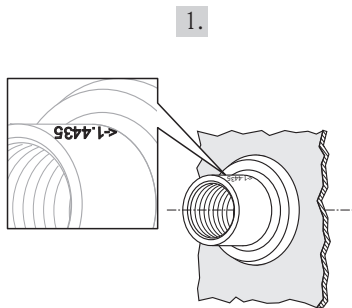

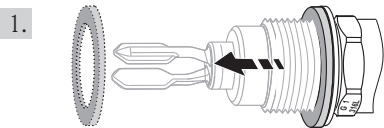

A, B, E

C, D

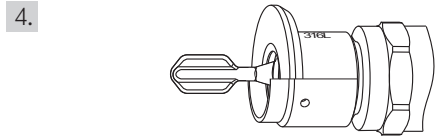
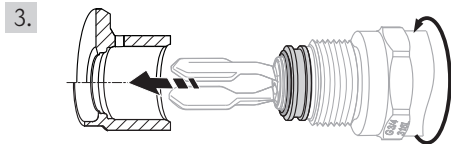
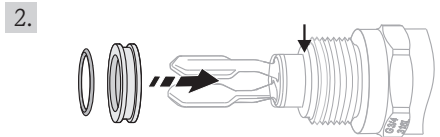
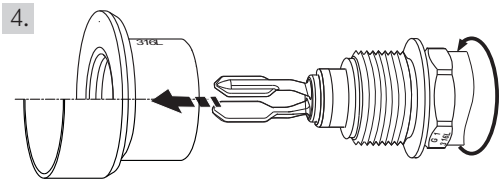
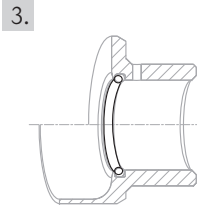
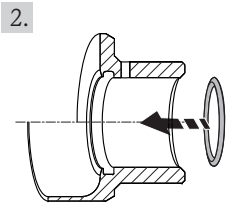

www.endress.com/worldwide

SD00352F/00/A6/01.12
71161872
FM+SGML 9.0



71161872